

INSTRUCTION MANUAL

Star Adventurer

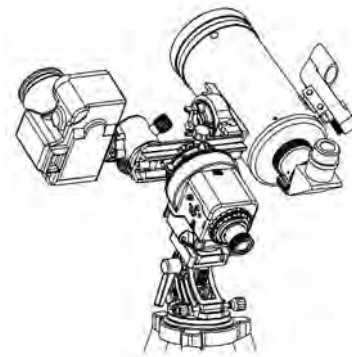
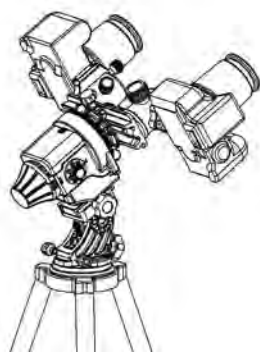
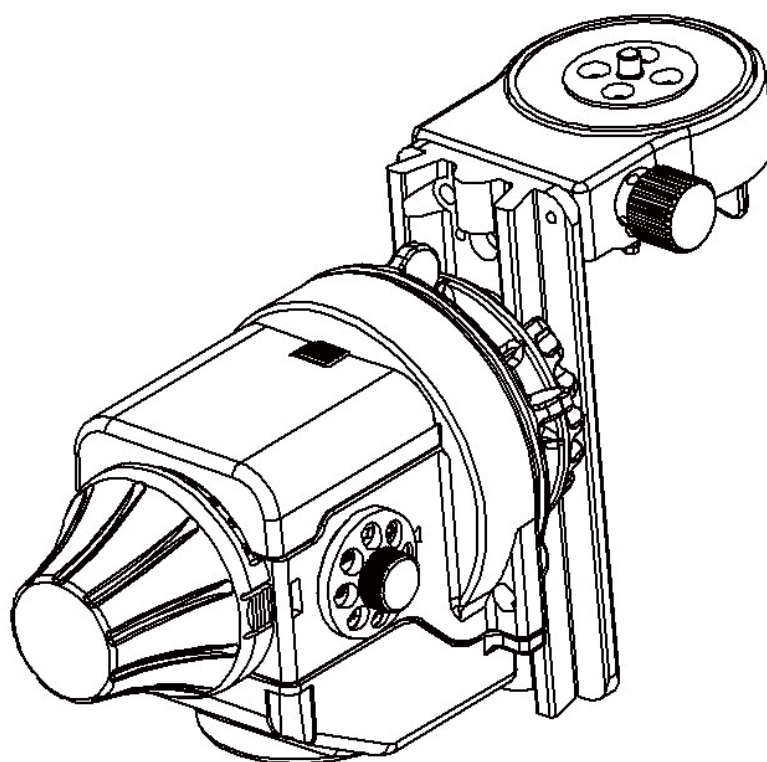

SA-F-140326V1-EN

Copyright © Sky-Watcher

Thank you for purchasing this Sky-Watcher Product

Sky-watcher Star Adventurer is user-friendly and provides various combinations to satisfy all your needs for astrophotography and time-lapse photography. It is a high precision, portable and stable celestial tracking platform for sidereal, solar and lunar tracking with automatic DSLR shutter release control. Moreover, it contains pre-programmed parameters assisting you to create interesting time-lapse videos with your DSLR.

For your Safety

To prevent damage to your Sky-Watcher product or injury to yourself or to others, read the following safety precautions entirely before using this equipment. Keep these safety instructions available to all users of the product.

To prevent possible injury, pay special attention to all warnings before using this **Sky-Watcher** product.

WARNING:

- **Do not look at the sun through the polar scope.** Viewing the sun or other strong light sources through the polar scope could cause permanent visual impairment.
- **Do not use in the presence of flammable gas.** Do not use electronic equipment in the presence of flammable gas, as this could result in explosion or fire.
- **Keep out of reach of children.** Failure to do so could result in injury. Moreover, note that small parts constitute a choking hazard. Consult a physician immediately when a child swallows any part of this equipment.
- **Do not disassemble.** Touching the product's internal parts could result in injury. In the event of malfunction, remove the battery and take the product to a Sky-Watcher authorized service center.

Notice

- Sky-Watcher reserves the right to change the specification of the hardware and software described in this manual at any time and without prior notice.
- Sky-Watcher cannot be held liable for any damage resulting from the (wrong) use of this product.
- While every effort has been made to ensure that the information in this manual is accurate and complete, we greatly appreciate if you find any errors, to report them to Sky-Watcher.

CONTENT

Features.....	4
How the Star Adventurer Works for Astrophotography.....	5
Introduction.....	6
The Sky-Watcher Star Adventurer Body.....	6
The Optional Accessories.....	7
Preparation.....	8
Setup tripod.....	8
Mount Star Adventurer.....	8
Mount the Image Equipment	11
For Astrophotography.....	11
For Time-Lapse Photography.....	13
Provide Power source.....	14
Start Using Star Adventurer.....	15
Quick functional reference.....	15
Mode Dial.....	16
3-Positions Slide Switch.....	17
Right/Left Buttons.....	17
Camera Shutter Interval Control.....	17
Swinging Angle.....	17
Auto-Guiding.....	18
USB port.....	18
Motor Status Detection.....	18
LED Indication.....	19
Polar Alignment	20
Example	24
Firmware Upgrade.....	26
Specification.....	27
APPENDIX.....	28

Features:

- High precision, portable and stable celestial tracking system
- Supports solar tracking, lunar tracking and star tracking
- Maximum payload is up to 5 kg (11 lb).
- Supports Star-Scape Photography
- Supports Time-Lapse Photography
- User-friendly Mode Dial with pre-programmed control setting.
- Supports multiple functions with easy assembling
- Built-in polar scope with illuminator for precise alignment
- Automatic DSLR shutter release control
- Lifetime free firmware upgrade
- Supports single axis auto-guiding
- Built-in motor protection and status indication
- Uses AAx4 Batteries
- Supports external USB power
- Low power consumption. Up to 72 hours continuous tracking with high quality alkaline AA battery.(Battery life may vary with loading and battery quality)
- 3/8" threaded socket for standard camera tripod
- 1/4" to 3/8" Convert screw adapter for quick release plate of tripod
- Other optional accessories available such as wedge and 1kg counterweight.

How the Star Adventurer Works for Astrophotography

Due to the rotation of the Earth, stars are not stationary. They appear to circle around the celestial poles of the earth. (Fig1) Thus, being very faint and constantly moving across the sky, stars are

impossible to be captured on photographs, unless the camera is able to track them steadily to allow long exposure. Star Adventurer provides the solution. With the high precision motor and built-in polar scope, Star Adventurer can be set to compensate exactly for the star movement by rotating the camera in the direction opposite to that of the Earth.(Fig 2) The result is, the celestial objects appearing in the field of view of your camera do not move anymore and so, taking a picture with a long exposure time is possible while star trails(Fig 1) are eliminated. Fig. 3 illustrates how rich and sharp your night sky pictures can be when Star Adventurer is used. In addition, Star Adventurer is also capable of tracking at solar and lunar speeds.



Fig 1

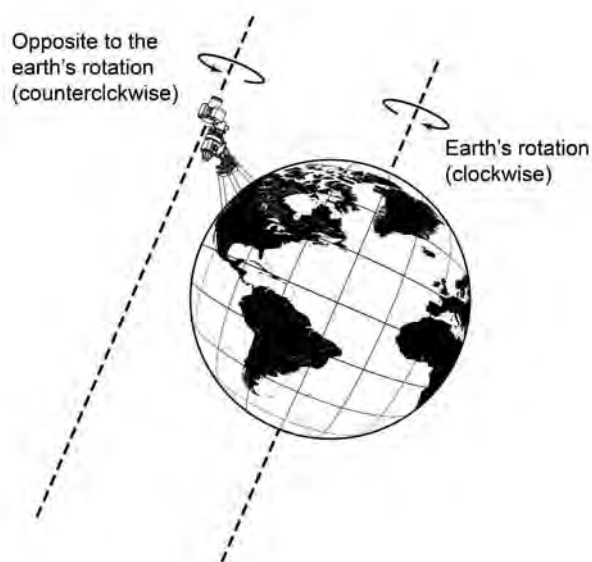

Fig 2

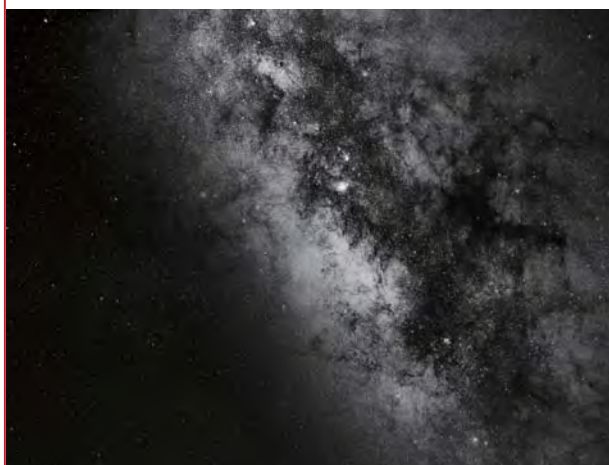
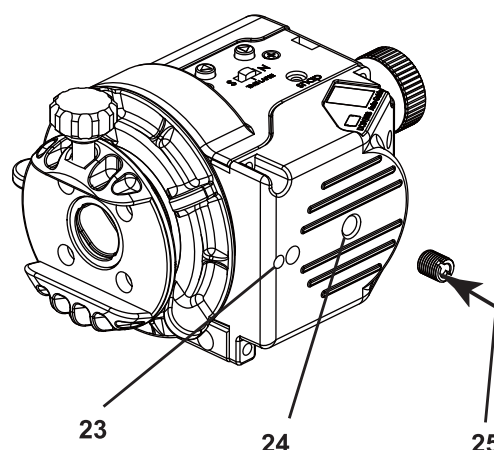
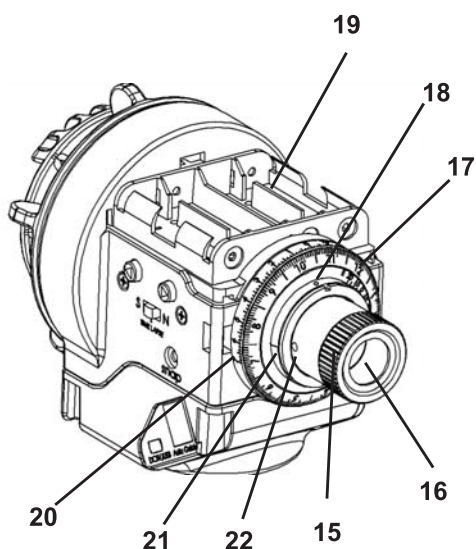
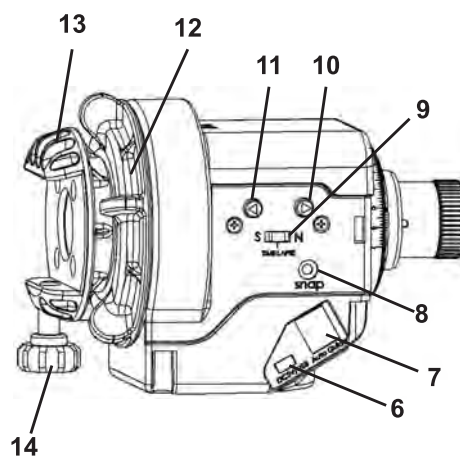
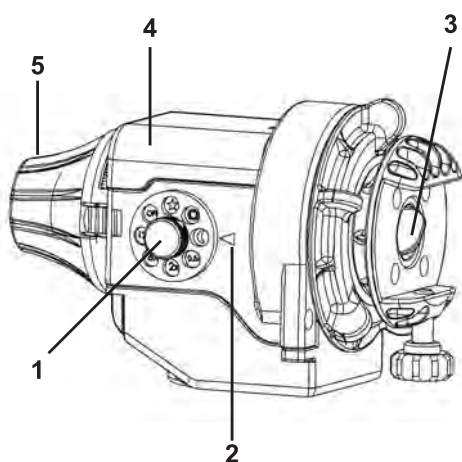

Fig 3

Introduction:

The Sky-Watcher Star Adventurer Body



- | | |
|---------------------------------------|---|
| 1: Mode Dial | 13: Mounting Platform |
| 2: Mode Index | 14: Locking Knob |
| 3: Polar Scope Cap | 15: Knurled Ring of Polar Scope |
| 4: Battery Case Cover | 16: Polar Scope |
| 5: Polar Scope Cover | 17: Date Graduation Circle |
| 6: Mini USB Port | 18: Time Meridian Indicator Calibration Screw |
| 7: RJ-12 6-pins Auto-guider Interface | 19: AAX4 Battery Case |
| 8: DSLR Shutter Control Port | 20: Time Graduation Circle |
| 9: S-TIMELAPSE-N Slide Switch | 21: Time Meridian Indicator |
| 10: Right Button and LED Indication | 22: Polar Scope Calibration Screw |
| 11: Left Button and LED Indication | 23: Worm Gear Meshing Adjustment Screw |
| 12: Clutch Knob | 24: Socket for 3/8" Thread Screw |
| | 25: 1/4" to 3/8" Convert Screw Adapter |

The Optional Accessories: (The default included accessories may vary. Please refer to local dealers for details)



Polar Scope Illuminator - To provide lighting source for polar scope. Also apply to **Sky-Watcher EQ3, EQ5 and EQ8**

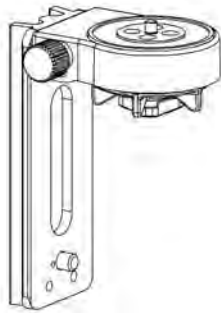

Fine-Tuning Mounting Assembly - To mount a telescope with 1/4" thread screw on the **Star Adventurer**. Allows pointing and fine-tuning pointing in two directions.



3/8" Ball Head Adapter - To mount a standard camera ball-head with 3/8" thread screw on the **Star Adventurer**

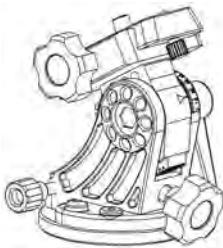

Equatorial Wedge - To adjust the latitude of the **Star Adventurer** for polar alignment. Offers more accuracy and stability than a standard photo tripod head.

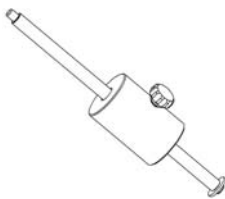

Counterweight - To balance the telescope or camera loading with 1kg Counterweight.



1/4" to 3/8" Convert Screw Adapter - To convert the default socket for 3/8" thread screw to the socket for 1/4" thread screw in order to mount the **Star Adventurer** to standard quick release plate of the tripod with 1/4" thread screw

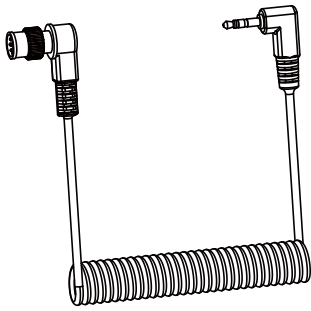

DSLR Shutter Control Cable - To connect the **DSLR Shutter Control Port** of **Star Adventurer** to your DSLR's external shutter control port. This allows **Star Adventurer** to directly control the DSLR's shutter release with pre-programmed shutter interval. You can order an optional cable for your camera from your local reseller. The Following list shows some available optional cables.

AP-R1C (CANON C1)	3.04.002.0073
AP-R3C(CANON C3)	3.04.002.0074
AP-R1N(NIKON N1)	3.04.002.0075
AP-R3N(NIKON N3)	3.04.002.0077
AP-R3L(OLYMPUS OP12)	3.04.002.0078
AP-R1S(SONY S1)	3.04.002.0079
AP-R2N(NIKON N2)	3.04.002.0076

Preparation :

Setup tripod:

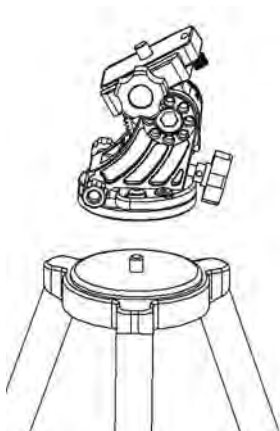

Fig 4

Without Tilt-head: take a standard photo tripod or video tripod with a 3/8" connection screw. Spread the legs and secure the tripod legs at the desired height to provide a stable support for your **Star Adventurer**. Assemble **Equatorial Wedge** to the tripod as Fig 4.

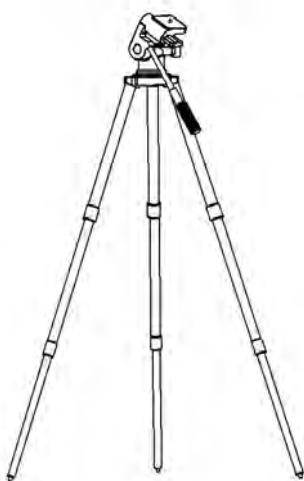

Fig 5

With Tilt-head/Ball-head: Take a standard photo tripod or video tripod with Tilt-head or Ball-head. Spread the legs and secure the tripod legs at the desired height to provide a stable support for your Star Adventurer as Fig 5.

Mount Star Adventurer:

With Equatorial Wedge: Make sure **1/4" to 3/8" Convert Screw Adapter** is not in the 3/8" threaded socket at the bottom of the **Star Adventurer**. If it is, use an Slot Screwdriver to remove it. Mount the **Star Adventurer** on the (optional) Equatorial Wedge. (Fig 6) Make sure the Stopper is facing forward. Then Point the **Polar Scope** to the direction of the North Pole (For Northern Hemisphere observing) or South Pole (For Southern Hemisphere observing). (Fig 7) Then complete the Polar Alignment process. (Please see **Polar Alignment** session for reference)

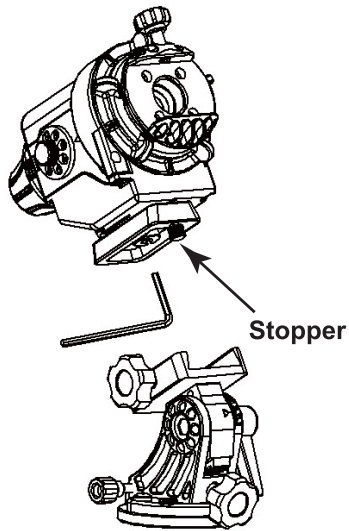

Fig 6

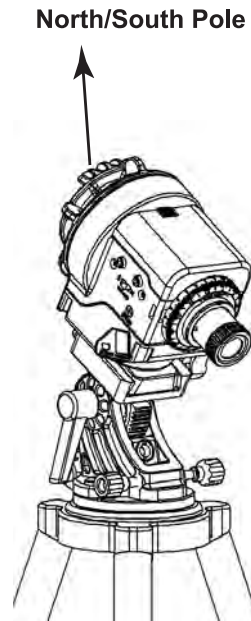

Fig 7

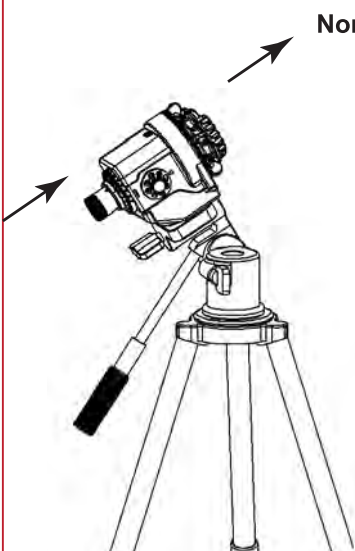

Fig8

With Tilt-head/ Ball-head: Make sure **1/4" to 3/8" Convert Screw Adapter** is in the 3/8" threaded socket at the bottom of the **Star Adventurer**. If it is not, use an Slot Screwdriver to install it. Mount the **Star Adventurer** to the quick release plate on the tripod. Then Point the Polar Scope to the direction of the North Pole (For Northern Hemisphere observing) or South Pole. (For Southern Hemisphere observing) (Fig 8) Then complete the Polar Alignment process. (Please see **Polar Alignment** session for reference)

Please DO NOT move the tripod or change the angle of Equatorial Wedge or tilt-head in order to keep the polar alignment. IF you did, please redo the polar alignment process.

Mount the Image Equipment:

Now you can mount your image equipments according to your situation including the **Shutter Control Cable** as the following pictures. You can contact **Sky-Watcher** authorized dealers to buy the optional accessories as needed. During the mounting, please DO NOT move the tripod or change the angle of **Equatorial Wedge** angle or tilt-head in order to keep the polar alignment.

For Astrophotography:

Star Adventurer +3/8" Ball Head Adapter + Ball head + Camera + Sutter Control Cable:

Note: Make sure the locking bolt of the **Mounting Platform** has locked on the indentation on the side of the **"3/8" Ball Head Adapter** for better locking and support.

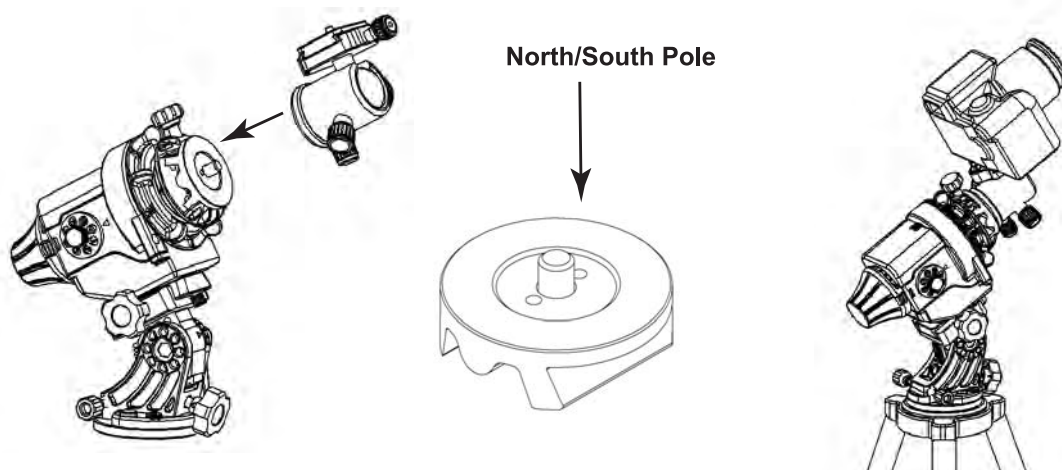

Fig 9



Fig 10

Star Adventurer + Fine-Tuning Mounting Assembly + 1kg Counterweight + Telescope:

Star Adventurer + Dovetail + Dual Ball-Heads + Dual cameras + Sutter Control Cable:

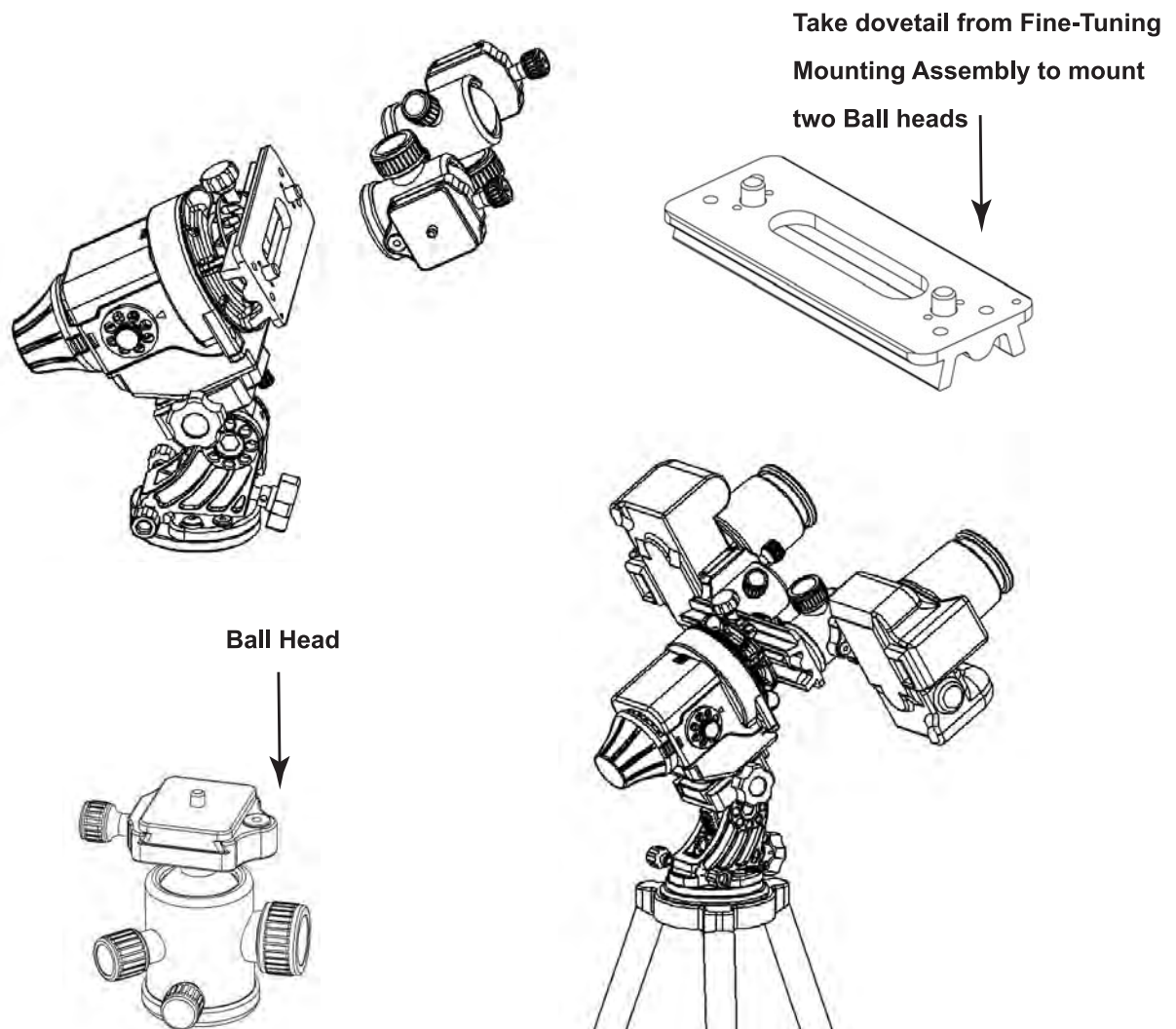

Fig 11

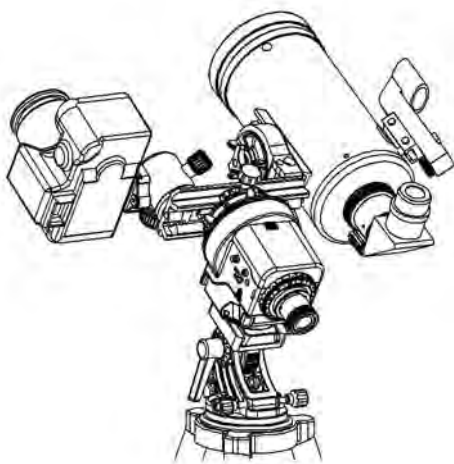

Fig 12

Star Adventurer + Fine-Tuning Mounting Assembly + Ball-Head + camera+ Telescope (+ Auto-guider):

For Time-Lapse Photography:

(For reference only: you can assemble very different configurations to create more interesting Time-Lapse Photography)

Horizontal Rotation Time-Lapse Photography:

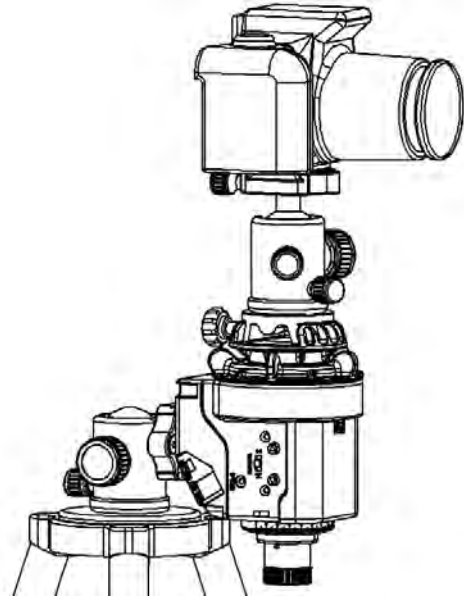

Fig 13

Vertical Rotation Time-Lapse Photography:

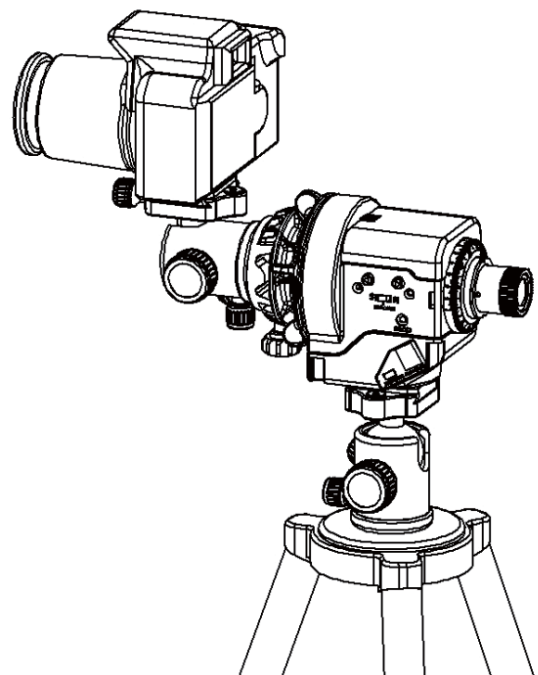

Fig 14

Provide Power source:

Star Adventurer allows two power source options. One is inserting 4 of AA type batteries; the other is providing DC 5V through USB port (type mini-B). (Fig 15)

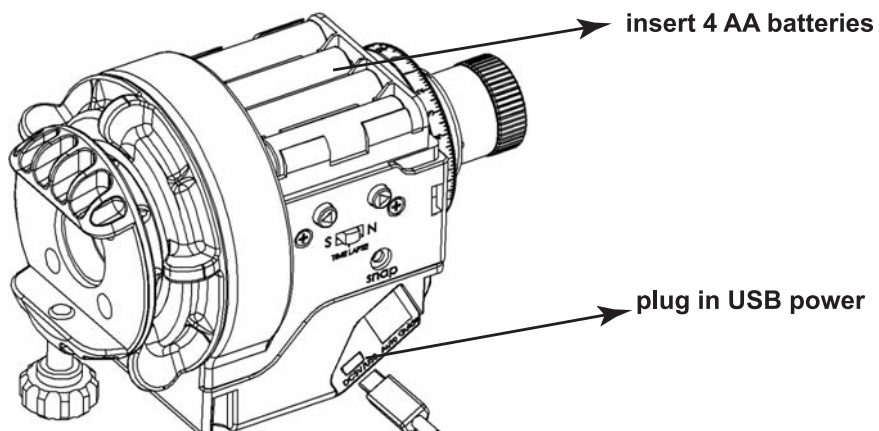
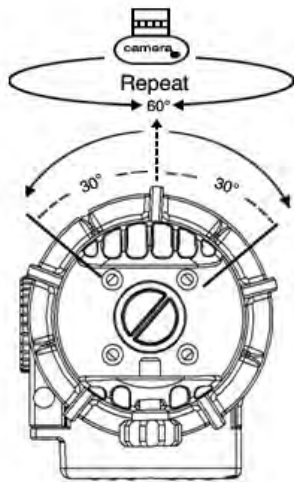

Fig 15

Start Using Star Adventurer

Quick Functional Reference:



Time-Lapse

Fig 16

Mode Dial	Star Adventurer rotational speed	Controlled Shutter interval (sec) According to Slide Switch Position	
		Switch to TIMELAPSE	Switch to N or S
OFF	Turn off power		
★	Celestial tracking. Swing between $\pm 360^\circ$	50	100
☼	Solar tracking. Swing between $\pm 360^\circ$	7	14
☾	Lunar tracking. Swing between $\pm 360^\circ$	10	20
0.5X	48Hr/ per revolution Swing between $\pm 360^\circ$	15	30
2X	12Hr/ per revolution Swing between $\pm 30^\circ$	3	6
6X	4Hr/ per revolution Swing between $\pm 30^\circ$	2	4
12X	2Hr / per revolution Swing between $\pm 30^\circ$	1	2

Table 1

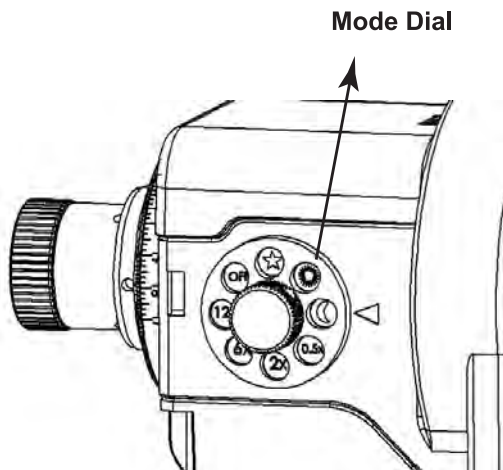

Fig 17

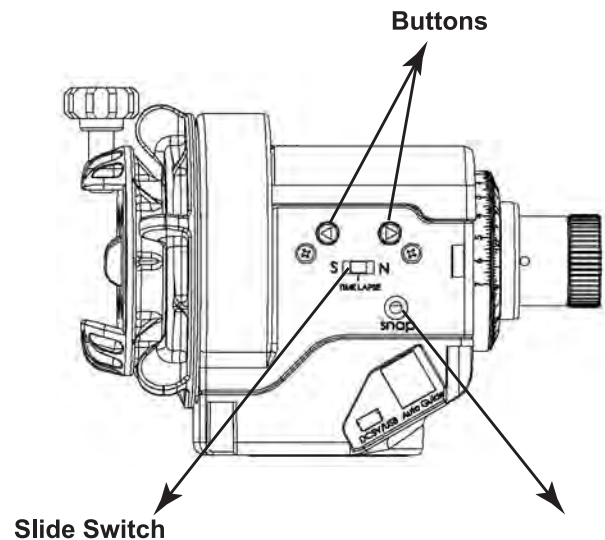

Fig 18

Mode Dial: For power control and selection of pre-programmed modes.

S-TIMELAPSE-N Slide Switch: for selection of rotational direction and camera shutter interval.

Buttons: The right, left buttons are used for rotating in higher speed (about 12X celestial tracking speed)

LEDs : The LEDs built in buttons provide the lighting source in the dark night and indicate the device status such as low battery and motor error.

Snap : This is a 2.5mm 3-segment stereo jack for connecting to a camera's shutter control port to control camera shutter interval.

After finishing the preparation, you can start to enjoy the **Star Adventurer**. The description of the major functions is as following:

Main Function:Star Adventurer has a user-friendly **Mode Dial**,and **S-TIMELAPSE-N Slide Switch** to allow user easily select the pre-programmed movement type. At the other side of the **Star Adventurer**, the two buttons give direct access to higher speed movement for quick positioning.

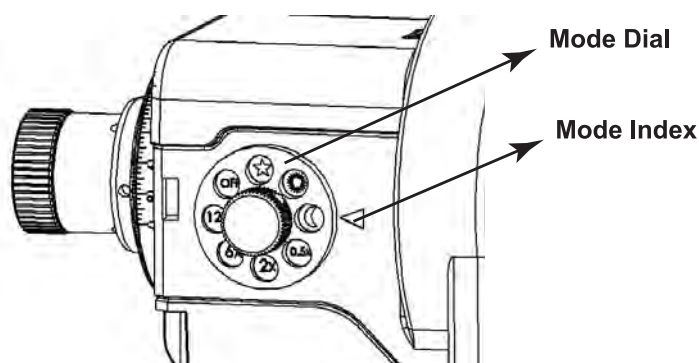

Fig 19

Mode Dial:It is used to turn on/off power and select the desired modes shown in table 1. The **Mode Index** to **OFF** mode, the power is turned off. While rotating to other modes besides **OFF** mode, the power is turned on. Then the LED on the **Mode Dial** will light up to indicate the current mode. And the LED on the buttons will light up, too. Meanwhile, the **Star Adventurer** will start tracking in the constant speed corresponding to the mode that user has selected. (Please refer to the table 1).

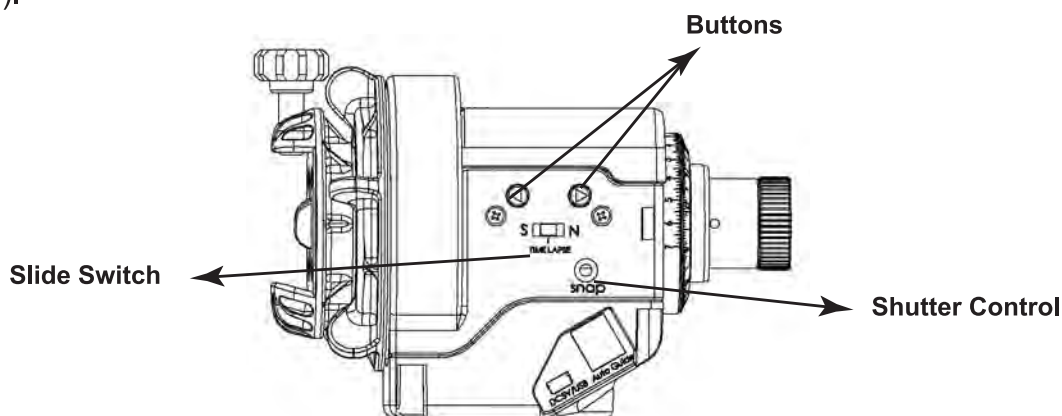

Fig 20

3-Positions Slide Switch: Selects the rotational direction of the **Star Adventurer** and the camera shutter interval. When the switch is slid to **N** or **TIMESAPSE**, the **Star Adventurer** will rotate in the direction of tracking celestial objects in northern hemisphere which is counter-clockwise when you look at Polaris; When the switch is slid to **S** the **Star Adventurer** will rotate in the direction of tracking celestial objects in southern hemisphere which is clockwise when you look at the celestial pole.

Right/Left Buttons: They are used to rotate the **Star Adventurer** at higher speed for easier positioning on the desired object. While Right Button is pushed, the **Star Adventurer** will rotate in the speed of 12 times sidereal rate and in the same direction as when we slide the switch to **N** or **TIMESAPSE**; While Left Button is pushed, the **Star Adventurer** will rotate in the speed of 12 times sidereal rate and in the same direction as when we slide switch to **S**;

SNAP (DSLR Shutter Control Port): **Star Adventurer** provides a camera shutter control interface to control the shutter interval. The SNAP port is a 2.5 mm 3-segment stereo jack and the trigger signal connects to the tip and base segments. With the proper **Shutter Control Cable** connecting your camera and Star Adventure, the mount can control the camera's shutter release. (please refer to **DSLR Shutter Control Cable in the Optional Accessories**) The Shutter interval period of every selected mode has been pre-programmed. Please refer to the Table 1. For example, when the **Mode Dial** is set to **Mode** ★ and **Slide Switch** is set to **N**, the shutter interval period is 100 seconds, or 50 seconds if the **Slide Switch** is set to **TIMELAPSE** (See Table 1). Every time the buttons are pushed on, or the mode is switched or the Slide Switch is slid, the selected shutter interval period will restart.

Swinging Angle: To avoid the shutter release cable to be twisted after a long period use under the Astrophotography application, **Star Adventurer** will reverse after reaching 360° rotation. That is, for **Mode** ★ ☀ ☾ and **0.5X** **Star Adventurer** will rotate within a 360° range. For the other modes, in order to provide more attractive scene while filming for time-lapse photography, under Time-Lapse application, **Star Adventurer** will reverse after reaching 90° rotation. That is, for **Mode 2X, 6X** and **12X**, **Star Adventurer** will rotate within 90° (See Table 1). Every button pushed or mode changed will reset the start point of the swinging angle. For example, the **Mode Dial** is at **6X** and **Slide Switch** is at **N**, the current position while we enter

the mode will be the start point of swinging angle. That is, it will rotate counter-clockwise first until it reaches 90°, then it will rotate clockwise until it reaches the start point (Fig 21). Then swing within the 90°. If you push the buttons, the position while you release the buttons will become the new start point of the 90° swing. If the switch is at **S**, it will rotate clockwise first until it reaches 90°, then it will rotate counter-clockwise until it reach the start point (Fig 22).

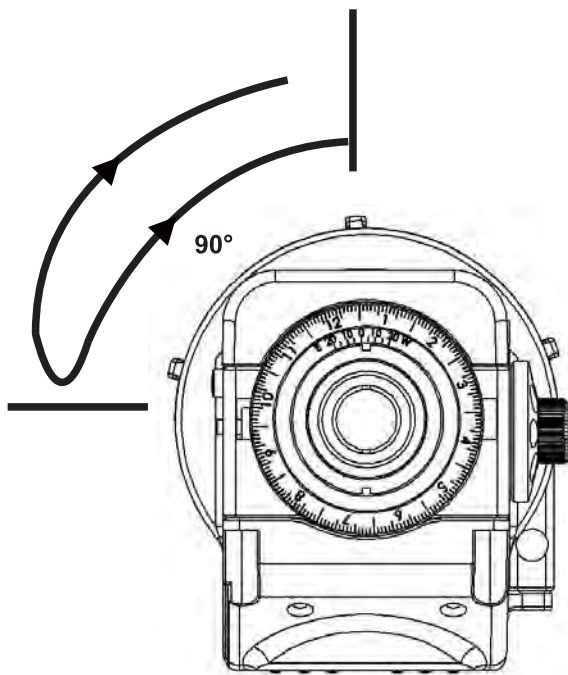

Fig 21

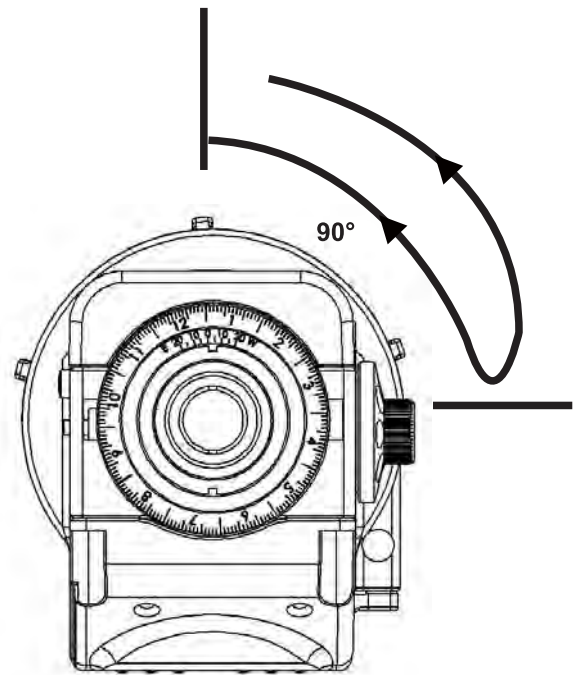

Fig 22

Auto-Guider: Star Adventurer also contains auto-guiding interface to accept single axis (RA axis) auto-guiding signal to provide more accurate celestial tracking for better quality of astrophotography. The RJ-12 6-pins outlet is for connecting an autoguider. It is compatible with any autoguider with a ST-4 type interface. This function only works in **Mode ★**. For other modes, the auto-guiding signal has no effect.

USB port: Star Adventurer contains an USB port (Type Mini-B) to support external USB power and Support firmware upgrade. Please refer to "**Firmware Upgrade**".

Motor Status Detection: If the motor stalls (rotation speed doesn't reach 10% of the targeted speed) over 5 seconds, in order to protect the motor and the mounted equipments, **Star Adventurer** will stop the motor and indicates "Motor Error" through flashing the LED on the buttons. Pushing buttons or switching any mode will restart the motor and restart the detection.

Moreover, if the motor speed error is over 5% (if it is not within the 95%~105% of the targeted speed), the **Star Adventurer** will indicate "Motor Error" through flashing the LED on the buttons, but it won't apply any change to the motor control.

LED Indication: Star Adventurer has LEDs under the buttons to indicate the current status. There are three different ways the LEDs will light up. If the LEDs don't light up, the **Star Adventurer** is not in working mode.

Normal Status: LED will light up slightly, continuously.

LED will light up slightly to provide light source at dark night when the motor status is normal and the power level is normal.

Warning Status: LEDs will blink at a 0,5 second rate in two cases:

1. **Firmware is upgrading.** While the user is updating the firmware, **Star Adventurer** will display to warn user do not turn off the power.

2. **Battery Low** (The Battery voltage is lower than 4.4V): **Star Adventurer** support most of the AA batteries. When using rechargeable Nickel Metal Hydride (Ni-Mh) batteries, please replace the batteries when it indicates low battery in order to protect the batteries from over discharging. When using Alkaline batteries, the system will run normally for a while after indicating battery low.

Motor Error Status: LED will blink at a 3 times per second rate in two cases:

1. **Motor speed Accuracy violation:** The motor speed error is over 5%. If this keeps happening, user may need to check for overload (Max load is 5kg) or the battery level is too low.

2. **Motor stall:** the motor stalls over 5 seconds. May be caused by external interference. Please check if the mount is blocked by an external force.

Polar Alignment:

Use the built-in **Polar Scope** to complete the polar alignment. First remove the **Polar Scope Cap** and insert the **Polar Scope Illuminator** (Fig 23). Rotate its **Power Dial** to turn on the power to illuminate the **Polar Scope**, then keep rotating the **Power Dial** until reaching the best illumination. (Calibrate the **Polar Scope** as needed. Please refer to " **Appendix I :Calibrate the Polar Scope**")

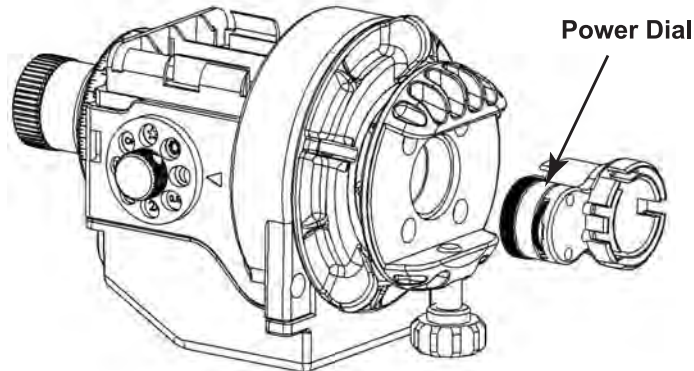

Fig 23

For observing in the Northern Hemisphere: find Polaris (the brightest star near the North Celestial Pole) in the polar scope by adjusting the angle of the (optional) **Equatorial Wedge** or tilt-head on the tripod. Use third party PolarisFinder application or APP to find the corresponding orientation of Polaris in the **Polar Scope** by simply entering the Date, Time, longitude and latitude of your observing location. Then move Polaris to that corresponding position in the polar scope by using the fine-tuning movements of the Equatorial Wedge or by moving the tilt-head of your tripod.(Fig 24) If you cannot acquire the application tool to find the orientation of the Polaris, please refer to the " **The Orientation of Polaris in Polar Scope** " in the following.

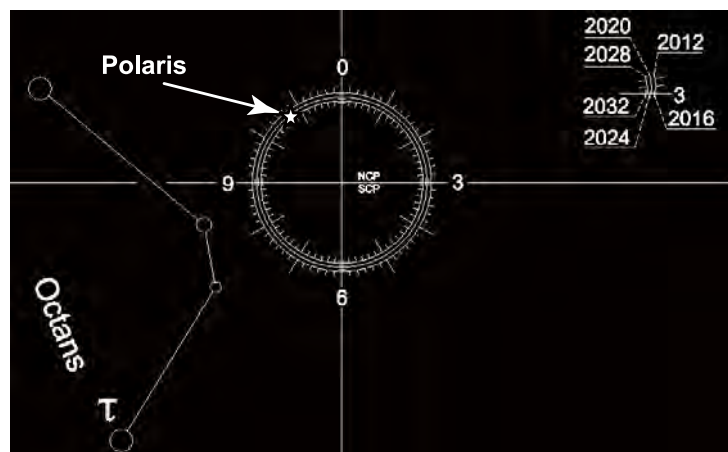

Fig 24

For observing in the Southern Hemisphere: locate in the polar scope the 4 dim stars (Around Magnitude 5 to 6) which form the pattern “Octans” (see drawing in the polar scope as Fig 25). Align the orientation of the “Octans” drawing to the 4 stars. Then move the 4 stars to the 4 small circles of the “Octans” drawing by using the finetune movements of the **Equatorial Wedge** or by moving the tilt-head of your tripod.



Fig 25

The Orientation of Polaris in Polar Scope

As Polaris is not located exactly at the North Celestial Pole, we can see it orbits the North Celestial Pole in a polar scope. The large circle seen in the center of the pattern in the Polar Scope is a representation of Polaris' orbit around the North Celestial Pole. When performing the polar alignment process, it is necessary to determine the orientation of Polaris on the circle. We can use the following 2 methods to get the orientation:

1. Locate both Polaris and Kochab in the sky near the North Celestial Pole. The direction from Polaris to Kochab can be used as approximation of the orientation of Polaris in the polar scope. Put Polaris in the same direction on the large central circle in the polar scope to finish the polar alignment(See Fig 26).

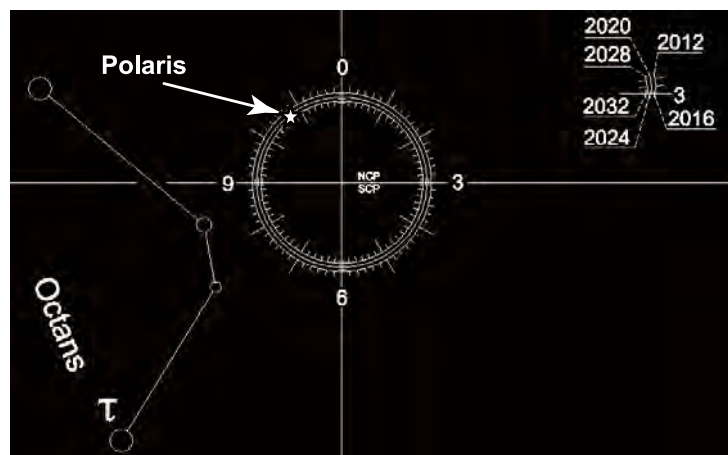

Fig 26

2. Use the built-in **Date Graduation Circle**, **Time Graduation Circle** and **Time Meridian Indicator** to find the orientation of Polaris in the Polar Scope following the steps described below:

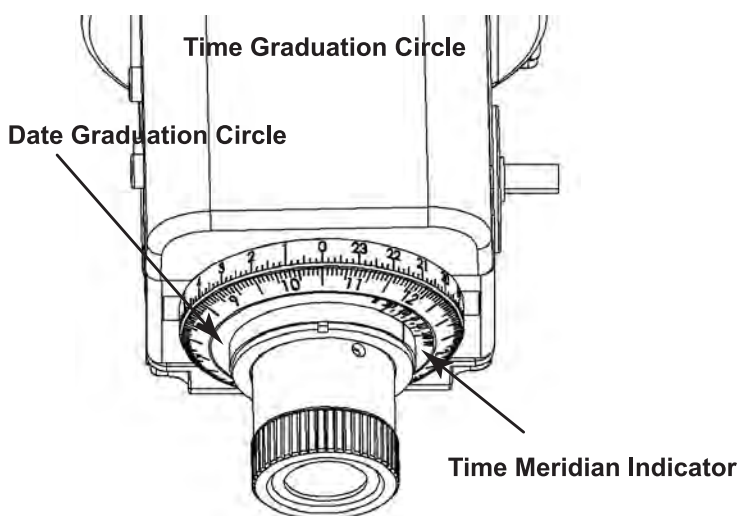

Fig 27

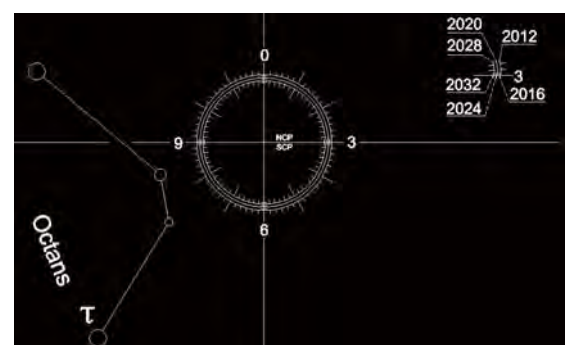

Fig 28

1. First rotate the Wedge and adjust the latitude to bring Polaris within the field of view of the polar scope.
2. Then rotate the **Date Graduation Circle** to align Oct 31 to the 0 of the **Time Graduation Circle** and Turn eyepiece/mount to align the **Time Meridian Indicator** to the 0 of the **Time Meridian Circle** (Fig 27). This is the date and time when the orientation of Polaris is directly below the north pole (6 o'clock).
3. See through eyepiece the pattern should be oriented as shown in Fig 28. If the pattern is rotated, please refer to "**Appendix I: Calibrate the Polar Scope**"
4. **Adjust the Date Graduation Circle** first according to difference between the standard time meridian of your region and the observing site. For example, if you are in Prince Rupert, Canada which is 130 ° west, then you have to turn the **Date Graduation Circle** to make the **Time Meridian Indicator** point to West 10 (which is 130° -120°)(Fig 29).
5. Then match the **Date Graduation Circle** with your observing time by turning eyepiece or mount. Please **DO NOT** rotate **Date Graduation Circle** directly at this step. For example, if your observing date is March 4 and time is 8:00PM. (Fig 30)
6. Then Put Polaris in the position of 6 o'clock in FOV of the polar scope to finish the polar alignment.

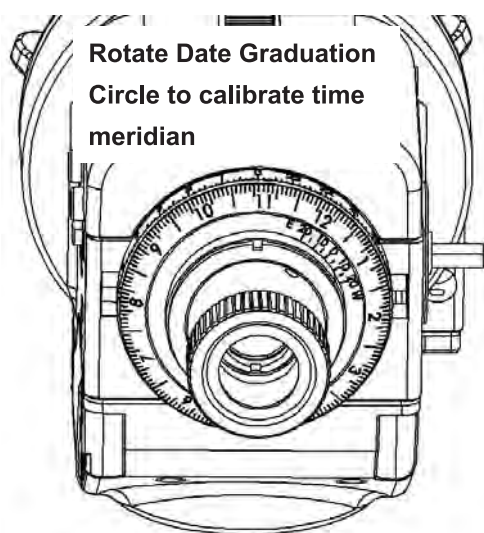

Fig 29

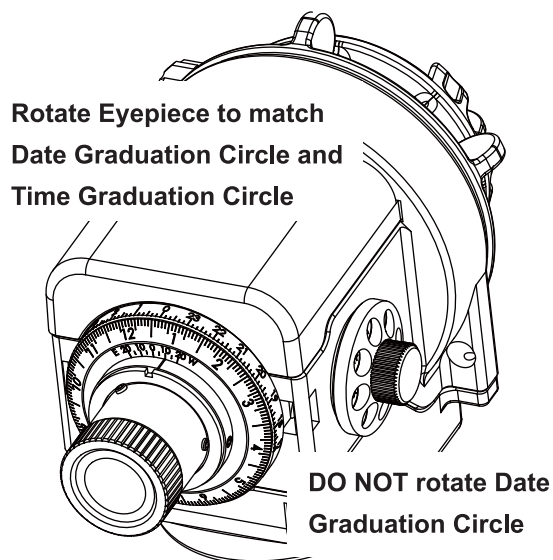

Fig 30

Example for Astrophotography for celestial Tracking:

1. Assemble the tripod, **Star Adventurer** according to the situation. Then finish the polar alignment.
2. Mount the camera or telescope. Install the cables (**Shutter Control Cable** and auto-guiding) if needed.
3. Slide the **Slide Switch** to **N** if you are in northern hemisphere (Fig 31).

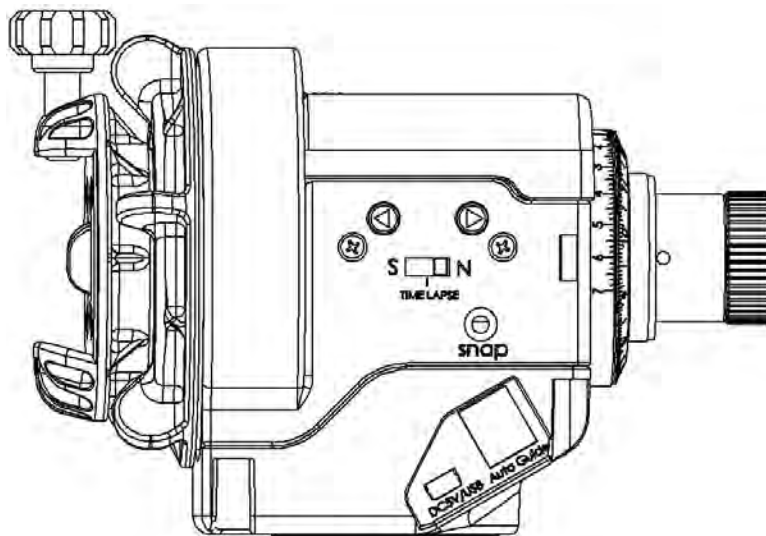

Fig 31

4. Rotate the **Mode Dial** to **Mode ★**. The LED on the **Mode Dial** will light up **Mode ★**. And the LED in the buttons will light up, too. The **Star Adventurer** will start tracking the celestial objects in sidereal rate speed. (86164 second/per revolution, about 23.9hour/per revolution) At the same time, it will start to control the camera by activating the camera shutter release function with an interval period of 100 seconds (as if you were pushing on the shutter release button of the camera during 99,5 seconds, and not pushing during 0,5 seconds and pushing again during 99,5 seconds etc.).
5. You can push the buttons to move the **Star Adventurer** at a higher speed (12 times sidereal rate) to approach the targeted object in RA direction. When you reach the targeted object, then release the buttons. The **Star Adventurer** will continue the celestial tracking and restart the shutter interval period of 100 seconds.

Example for Time-Lapse photography in Mode 12X:

1. Assemble the tripod, **Star Adventurer** according to the situation.
2. Assemble the camera and connect the camera and **Star Adventurer** with the **Shutter Control Cable**.
3. Slide the **Slide Switch** to position **N** Rotate the **Mode Dial** to **Mode 12X**.
4. **Star Adventurer** will start to rotate counter-clockwise with a speed of 2 hour per revolution. When it reaches 90° it will start to rotate clockwise back to the starting point. It will repeat the swing within this 90° . (Fig 32). At the same time, it will start to control the camera by activating the camera shutter release function with an interval period of 2 seconds (as if you were pushing on the shutter release button of the camera during 2 seconds, and not pushing during 0.5 seconds and pushing again during 2 seconds etc.).

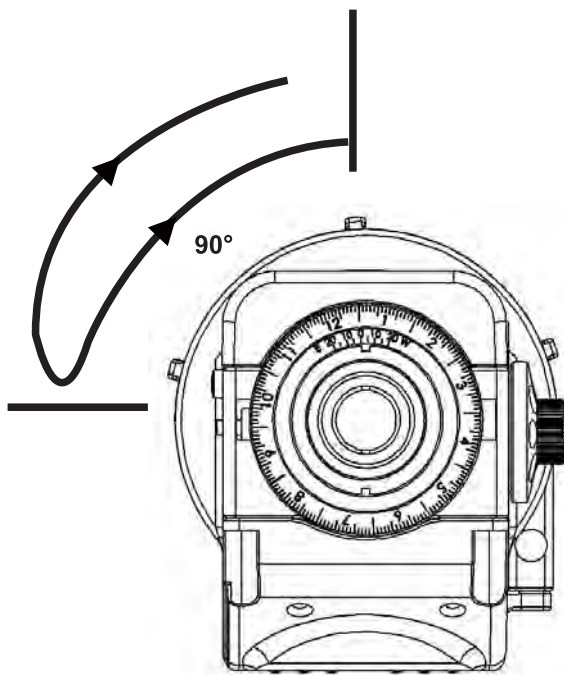

Fig 32

Firmware Upgrade:

1. Download “ **Motor Controller Firmware Loader** ” V1.60 or higher and the newest firmware from www.skywatcher.com
2. Connect **Star Adventurer** to the computer with the mini USB cable. If this is the first time the device is connected to this computer, please wait for a few minutes for the computer to load the driver.
3. Rotate the **Mode Dial** to leave the OFF mode to turn on the power.
4. Double click on **Motor Controller Firmware Loader** and load the previously downloaded firmware.
5. Select “ **auto-detect COM port** ”, click on the “**update** c” button. Please do NOT turn off power while updating the firmware. After about 25 seconds, the Software will display “ **Update Complete. Turn off power** ”. Then the firmware upgrade is completed.
6. If you didn't select “ **auto-detect COM port** ”, or you have multiple Star Adventurers connected to the same computer, please manually select the correct serial COM port. Then click on the “**update** ” button. Please do **NOT** turn off power while updating the firmware. After about 25 seconds, the Software will display “**Update Complete. Turn off power** ”. Then the firmware upgrade is completed.
7. Rotate the **Mode Dial** to “OFF” to turn off the power. Then Turn on the power to use normally.
8. If you encounter power loss during the firmware update, you can just repeat from Step 3 to Step 7 after restoring the power.

Specification

Sky-Watcher Star Adventurer	
Type	Ultra compact equatorial tracking platform
Tracking mode	Astrophotography: Celestial Tracking rate, 1/2 celestial tracking rate, solar tracking rate, lunar tracking rate(mean lunar time). For both of northern and southern hemispheres. Time-lapse photography: 12 hr/rev, 4 hr/rev and 2 hr/rev
Max payload	5 kg (11 lb)
Wheel Gear	86mm dia. 144 teeth aluminum alloy
Worm Gear	13mm dia. High tension brass
Motor drive	DC Servo
Built-in accessory	Polar scope
Polar scope	About 7° field of view
Working voltage	4 x AA battery: DC 3.6V~ 6.5V External power supply: DC 4.75V~5.25V
Duration of operation	Up to 72 hours continuous tracking with high quality alkaline AA battery at 20 °C.(Battery life may vary with loading and battery quality)
Operation temperature	0 ° ~ 40 °C
Dimensions	173.5mm x 113.3mm x 96 mm
Weight	1 kg
Base connect	3/8" threaded socket (or 1/4" with conversion adapter supplied)

APPENDIX I

Calibrate the Polar Scope

Before using the **Polar Scope** for polar alignment, the **Polar Scope** itself must be calibrated to ensure the pattern in the **Polar Scope** is aligned to the mount's R.A. axis. The following steps will outline how to calibrate the **Polar Scope**. **Calibrating during daytime is strongly recommended :**

1. Choose a fixed object (the Polaris at night, or a faraway object in daytime); orient **Star Adventurer** to put the crosshair of the **Polar Scope** exactly on the chosen object.
2. Rotate the mount in R.A. axis for half a turn.
3. If the object remains exactly behind the crosshair in the **Polar Scope** after the rotation, then it means the **Polar Scope** is aligned to the R.A. axis and no calibration is needed.
4. If, during rotation, you see the object wandering off, calibration is needed. You should rotate the **Star Adventurer** to find the point where the object is at the biggest distance from the crosshair center, and then you should move the crosshair halfway towards the object(Fig 29), using the 3 tiny adjustment screws on the side of the polar scope(Fig 28). A 1.5mm Allen wrench is needed.

IMPORTANT WARNING: Adjusting with the very small allen screws is delicate. Read the note below.

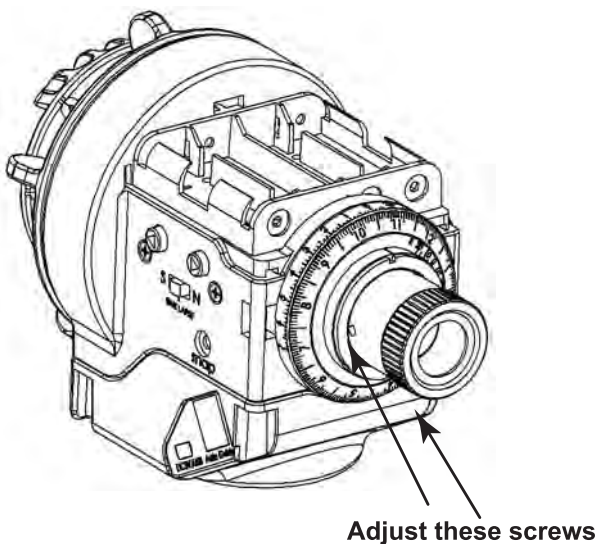

Fig 28

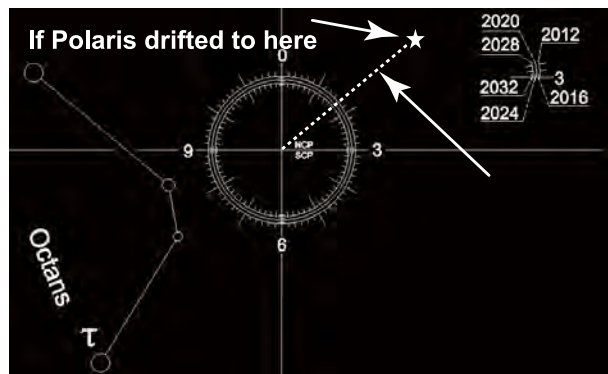

Fig 29

5. Repeat steps 1 to 4 a few times until the object keeps at the center of the reticle when rotating the mount in R.A. axis.

6. Turn the **Date Graduation Circle** to align Oct 31 to the 0 of the **Time Graduation Circle**. Then hold the **Date Graduation Circle** and turn the eyepiece/mount to align the **Time Meridian Indicator** to the 0 of the **Time Meridian Circle** (Fig 30). Then, when looking through the eyepiece, you should see the pattern aligned as shown in Fig 31. If the pattern is oriented differently, then scales need readjustment. To readjust, turn the **Date Graduation Circle** to align Oct 31 to the 0 of the **Time Graduation Circle**. Then hold it and turn the eyepiece/mount to orient the pattern in the position shown in the picture below right. Loosen the **Time Meridian Indicator** calibration screw and move the meridian indicator to align it to the 0 of the **Time Meridian Circle** without turning the **Date Graduation Circle** and eyepiece/mount. Tighten the Time Meridian Indicator calibration screw. See through the eyepiece. Now the pattern should still be in the right position.

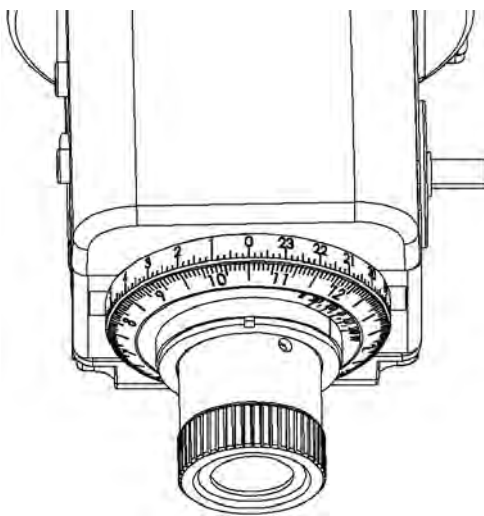

Fig 30

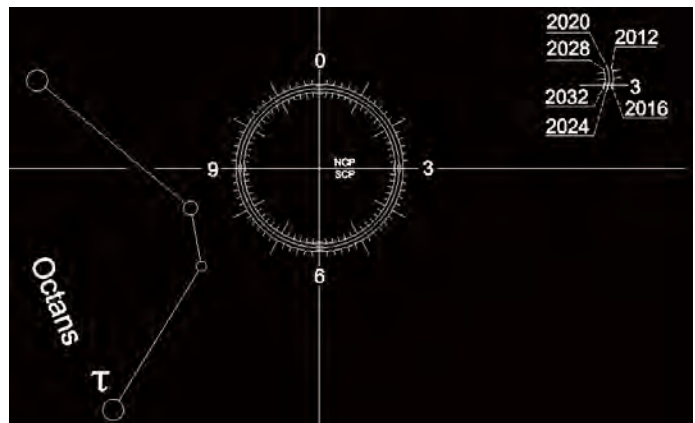

Fig 31

Note:

- When adjusting the Allen screws, loosen one screw only $\frac{1}{4}$ of a turn, and then tighten the other two gently.
- Do not over tighten the Allen screws; it might damage the pattern plate in the polar scope.
- Do not loosen one screw completely or loosen more than one screw at a time; otherwise, the pattern plate in the **Polar Scope** will be disengaged and further adjustment is impossible.
- If the pattern plate does disengage, remove the **Polar Scope** 's eyepiece by turning the **Knurled Ring** counterclockwise and then engage the pattern plate again.

- It is recommended to do this calibration at daytime, aiming at a point object (such as a distant rooftop) because the delicate operation with the tiny allen screws is even more delicate in the dark.

APPENDIX I I

Fine-Tuning Mounting Assembly :

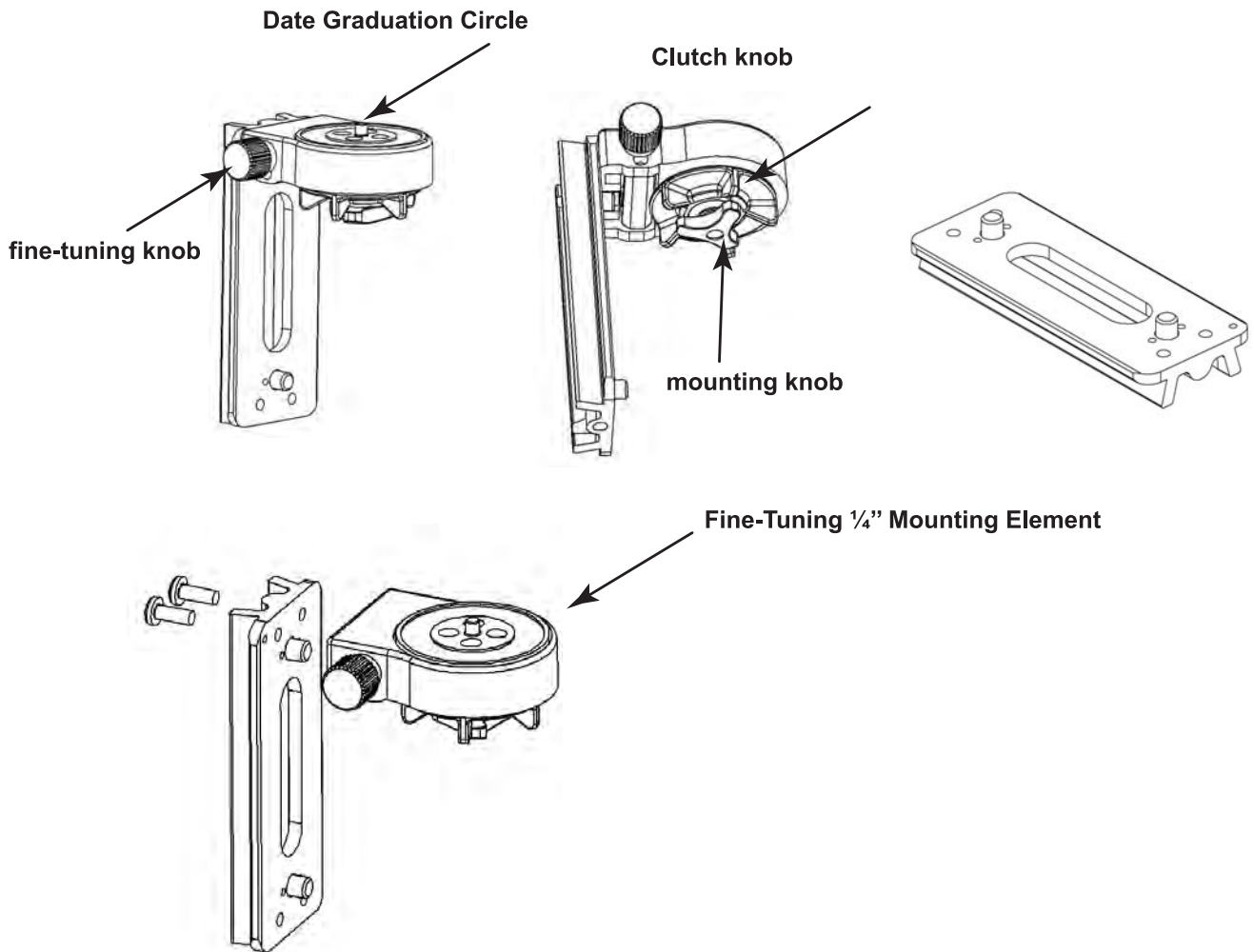

The Fine-Tuning Mounting Assembly connects a telescope to Star Adventurer and allows rotation in the other direction (at 90°, DEC direction) . You can adjust the tightness of the rotation with the clutch knob. You also can fine-tune the camera or telescope orientation slightly in DEC direction by using the fine-tuning knob. You can also remove the Fine-Tuning 1/4" Mounting Element from the dovetail and then you can mount two ball heads on the dovetail to carry two cameras or one camera and another instrument. You can also use the Fine-Tuning 1/4" Mounting Element at one side and use ball head at the other side. You can implement various combinations to fit your needs.

Equatorial Wedge :

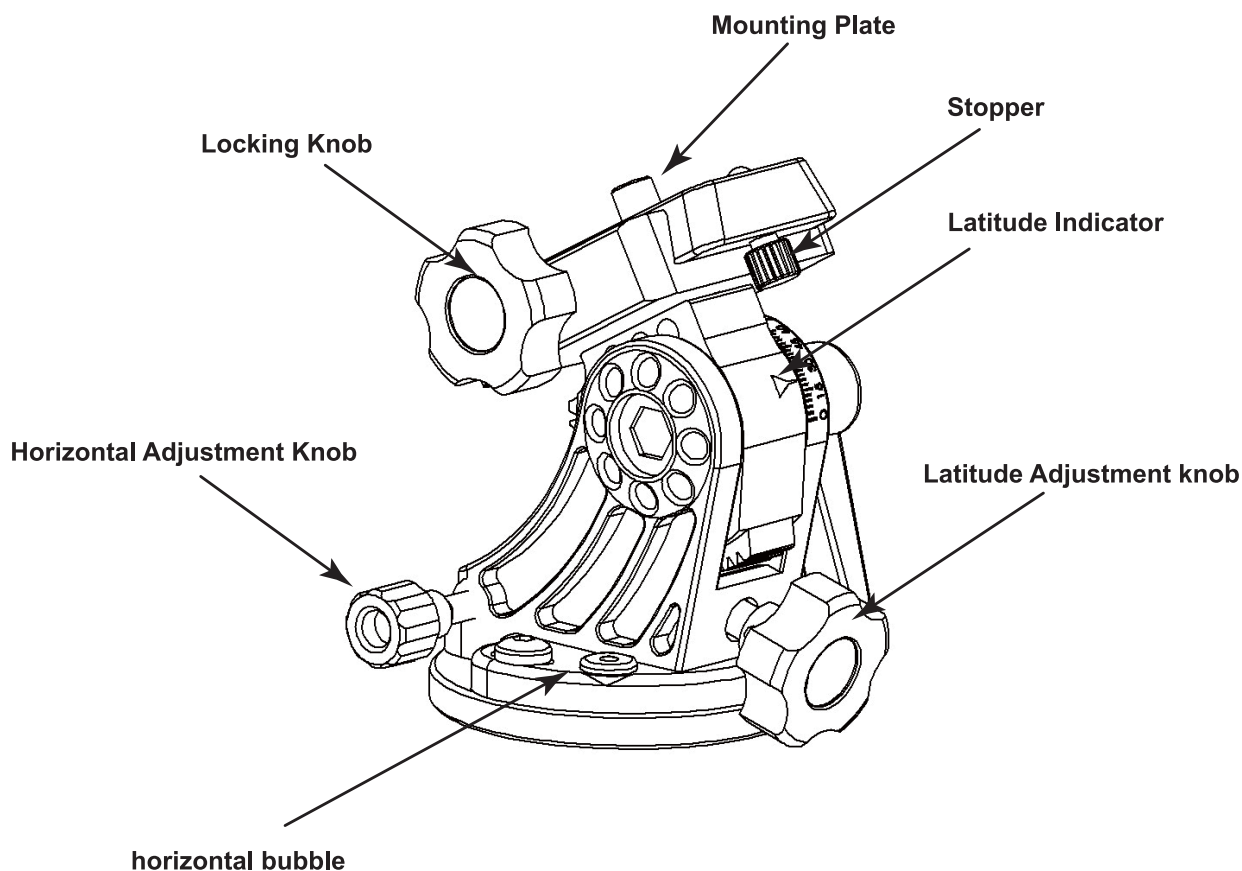

The Adjustable Wedge is a device to adjust the latitude for Polar Alignment. Rotate the Latitude Knob can adjust the latitude of the **Star Adventurer** which the Latitude Indicator indicates. The range is from 0° to 70°. The Horizontal Adjustment Knob can adjust the Wedge to rotate to right or left horizontally. The Horizontal bubble is to check if the base plate of the wedge is horizontal. The accuracy is 1°. When you install the **Mounting Plate** on the **Star Adventurer**, Make sure the **Stopper** is facing forward like the Fig 32 shown to avoid the equipments sliding down before you fasten the Locking Knob.

CAUTION!



NEVER USE YOUR TELESCOPE TO LOOK DIRECTLY AT THE SUN. PERMANENT EYE DAMAGE WILL RESULT. USE A PROPER SOLAR FILTER FIRMLY MOUNTED ON THE FRONT OF THE TELESCOPE FOR VIEWING THE SUN. WHEN OBSERVING THE SUN, PLACE A DUST CAP OVER YOUR FINDERSCOPE OR REMOVE IT TO PROTECT YOU FROM ACCIDENTAL EXPOSURE. NEVER USE AN EYEPIECE-TYPE SOLAR FILTER AND NEVER USE YOUR TELESCOPE TO PROJECT SUNLIGHT ONTO ANOTHER SURFACE, THE INTERNAL HEAT BUILD-UP WILL DAMAGE THE TELESCOPE OPTICAL ELEMENTS.