



ASI1600 Manual

Revision 1.1

Aug, 2016

All material in this publication is subject to change without notice and is
copyright Zhen Wang Optical company.



Table of Contents

ASI1600 Manual	1
1. Instruction	3
2. Camera Models and Sensor Type	4
3. What's in the box?.....	5
4. Camera technical specifications	7
5. QE Graph & Read Noise.....	8
6. Getting to know your camera.....	10
6.1 External View.....	10
6.2 Power consumption:.....	11
6.3 Cooling system.....	12
6.4 Back focus distance.....	12
6.5 Protect Window.....	13
6.6 Analog to Digital Converter (ADC).....	13
6.7 Binning.....	13
6.8 Replacing the desiccant tablets	14
7. How to use your camera	15
8. Cleaning.....	19
9. Mechanical drawing.....	21
10. Servicing	22
11. Warranty	22

1. Instruction

Congratulations and thank you for buying one of our ASI Cameras! This manual will give you a brief introduction to your ASI camera. Please take the time to read it thoroughly and if you have any other questions, feel free to contact us. info@zwoptical.com

ASI1600 Cameras are designed for astronomical photography. This is the first camera in the world not only suitable for DSO imaging but also planetary imaging. The excellent performance and multifunctional usage will impress you a lot!

For software installation instructions and other technical information please refer to “Getting started with ASI1600”

2. Camera Models and Sensor Type

There are 4 types of ASI1600 models:

Models	Mono or Color	Regulated TEC Cooling	Sensor
ASI1600MM	Mono	no	Panasonic MN34230ALJ
ASI1600MC	Color	no	Panasonic MN34230PLJ
ASI1600MM-Cool	Mono	yes	Panasonic MN34230ALJ
ASI1600MC-Cool	Color	yes	Panasonic MN34230PLJ

Which camera to choose:

Monochrome camera sensors are capable of higher detail and sensitivity than is possible with color sensors, but you need additional accessories such as filter wheel and filters. The post-processing is more complicated too, so a color camera is often recommended for the beginner astro-photographer.

TEC cooling will help to reduce dark current noise for long exposures. For short exposures, such as under one second, the dark current noise is very low, however cooling is recommended for DSO imaging when long exposures are required.

3. What's in the box?

For ASI1600MM and ASI1600MC



1-ZWO ASI1600MM Camera Body

The 11mm T2 extender ring has been already attached to it.

2-2 m long ST4 guider cable

3-1.25" Cover

4-T2-1.25" Filter adapter 3mm thickness

So you can screw a 1.25" filter very close to the sensor without vignetting.

5-T2-M48 extender

2" diameter outside, 18.5mm length and with M48x0.75 threads in the end.

6-T2-1.25" nosepiece

7-2 m long USB3.0 cable

8-Driver & Extra Software CD (Mac, PC & Linux Compatible)

For ASI1600MM-Cool and ASI1600MC-Cool



1-ZWO ASI1600-C Camera Body

The 11mm T2 extender ring has been already attached to it.

2-T2-M48 extender

2" diameter outside, 18.5mm length and with M48x0.75 threads in the end.

3-T2-1.25" nosepiece

4-1.25" Cover

5-2 m long USB 3.0 cable

6-USB 2.0 short cable x2

They are used to connect your EFW or guider camera through the USB2.0 hub.

7-backup desiccant tablets packet

You need to replace them once you found fogging happen inside camera.

8-T2-1.25" Filter adapter 3mm thickness

So you can screw a 1.25" filter very close to the sensor without vignetting.

9-Driver & Extra Software CD (Mac, PC & Linux Compatible)

4. Camera technical specifications

Here is a table of 1600 technical specifications

Sensor	4/3" CMOS
Diagonal	21.9mm
Resolution	16Mega Pixels 4656×3520
Pixel Size	3.8μm
Image area	17.6mm*13.3mm
Max FPS at full resolution	23FPS(10bitADC) 15FPS(12bitADC)
Shutter	Rolling shutter
Exposure Range	32μs-2000s
Read Noise	1.2e @30db gain
QE peak	~60%
Full well	20ke
ADC	12 bit or 10 bit
Interface	USB3.0/USB2.0
Adaptors	2" / 1.25" / M42X0.75
Protect window	AR window
Dimensions	78mm Diameter
Weight	410g
Back Focus Distance	6.5mm or 17.5mm
Cooling:	Regulated Two Stage TEC
Delta T	40-45 below ambient
Cooling Power consumption	12V at 2A Max
Supported OS	Windows, Linux & Mac OSX
Working Temperature	-5°C—45°C
Storage Temperature	-20°C—60°
Working Relative Humidity	20%—80%
Storage Relative Humidity	20%—95%

5. QE Graph & Read Noise

QE and Read noise are the most important parts to measure the performance of a camera. Higher QE and Lower read noise are needed to improve the SNR of an image.

For the Mono 1600 Sensor, the peak value for QE is around 60%

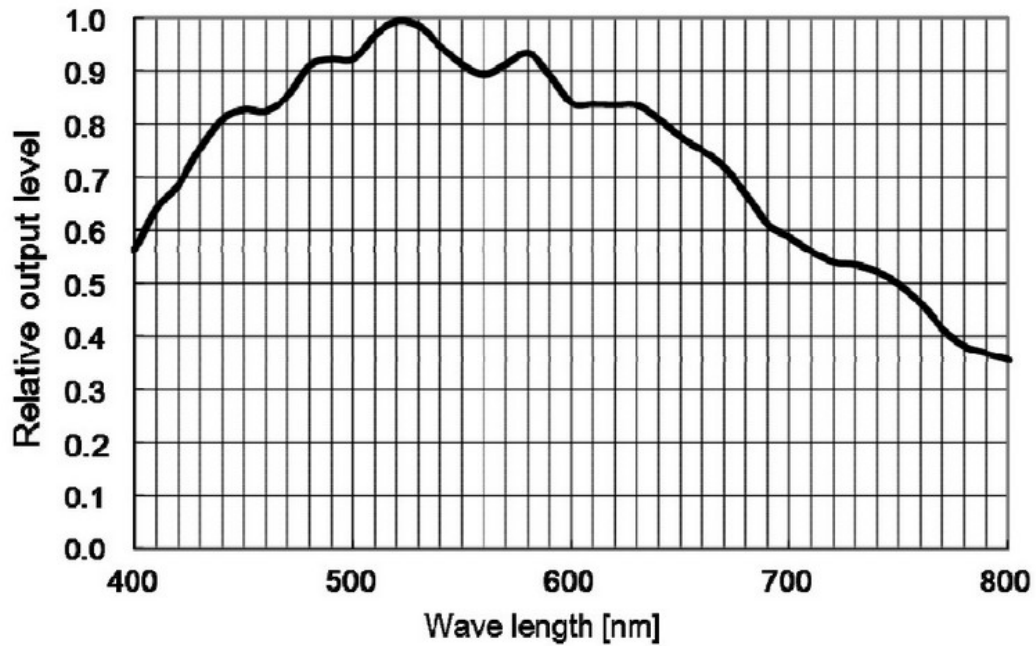

Color 1600 sensor

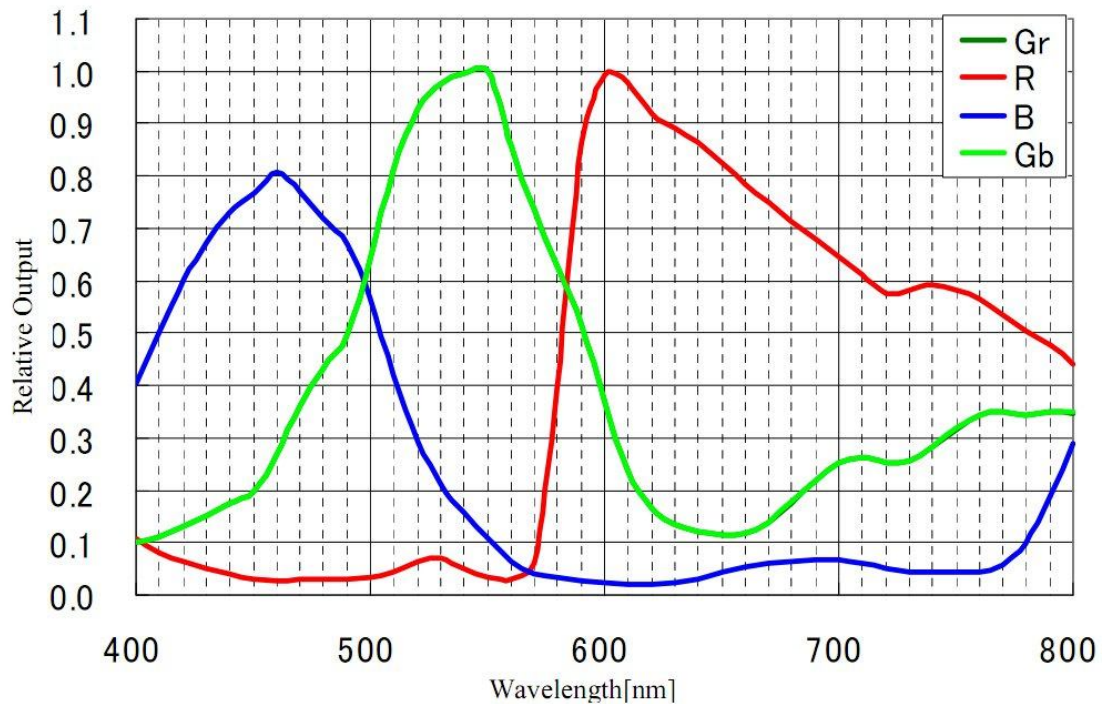

Read noise includes pixel diode noise, circuit noise and ADC quantization error noise, and the lower the better.

The Read Noise of the ASI1600 cameras is extremely low when compared with traditional CCD cameras and it is even lower when the camera is used at a higher gain.

Depending on your target, you can set the gain lower for higher dynamic range (longer exposure) or set the gain higher for lower noise (such as short exposure or lucky imaging).

Read noise, full well, gain and dynamic range for ASI1600

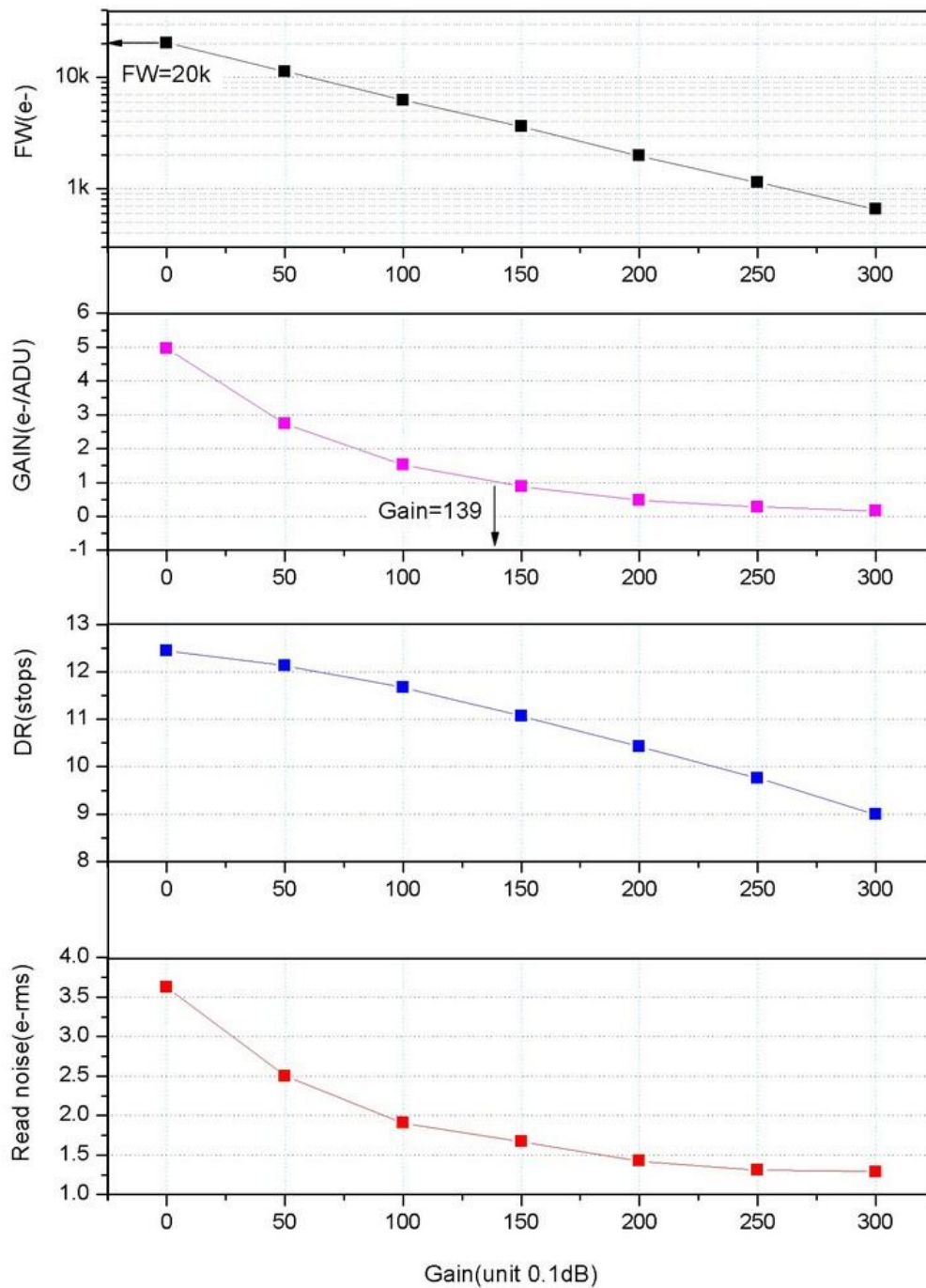

6. Getting to know your camera

6.1 External View



*the first generation of cooled camera we used a ST4 port instead of USB2.0 hub

You can order the [holder ring](#) from us or our dealer to mount the cooled camera to tripod.

There is 1/4" screw under the holder

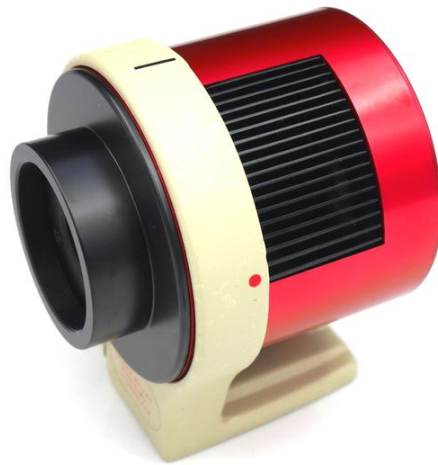

6.2 Power consumption:

ASI cameras are designed to have very low power consumption which is around 300ma@5V. You only need the USB cable to power up the camera, however you will need a separate power supply to activate the cooler. We recommend 12V at 3A or more AC-DC adapter for cooler power supply (2.1mm*5.5mm, center positive). You may also use a battery supply from 9 to 15V to power the cooler.

Here is a test result of the cooler power consumption of our cooled camera. It only needs 0.5A to cool the camera to 30 degree below ambient.

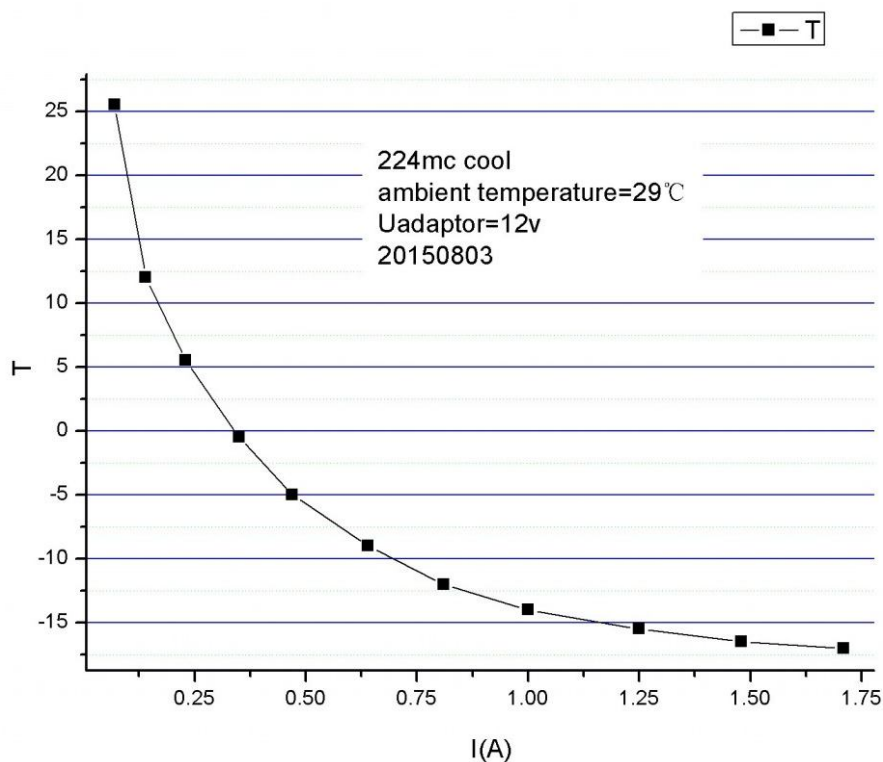

6.3 Cooling system

The cooled ASI1600 cameras have a robust, regulated cooling system, which means that the camera sensor can be kept at the desired temperature throughout your imaging session. The super low readout noise, combined with efficient cooling and adjustable gain setting, allows you to do short or lucky DSO imaging unlike the traditional CCD cameras which need very long exposures for each frame. However, keep in mind that cooling won't help with very short exposures such as less than 100ms. The lowest temperature that can be set is -30°C .

Here is a dark current test result of 1600 Cool sensor at various temperatures.

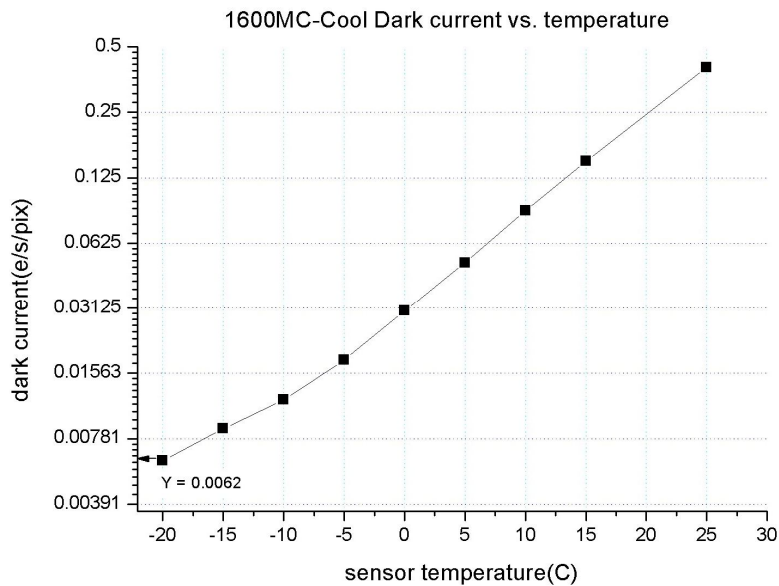

6.4 Back focus distance

When the attached 11mm T2 Extender is removed the optical distance from the sensor to the camera body is reduced to 6.5mm.



6.5 Protect Window

There is a protect window before the sensor of ASI1600 camera.

It's an AR-AR coated BK7 glass, diameter is 32mm and 2mm thick.

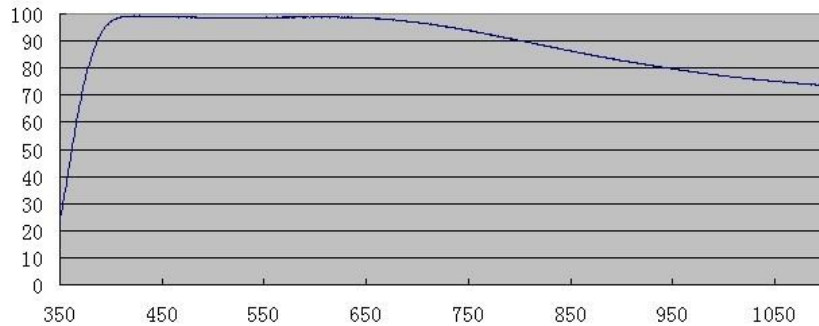

6.6 Analog to Digital Converter (ADC)

The ASI1600 camera records in 12bit ADC and 10bit ADC. You can image at a faster fps rate if you choose to use 10bit ADC (high speed mode). This camera also supports ROI (region of interest) shooting, and this smaller ROI has faster fps. You can uncheck “high speed” and choose 8bit output on software to enable 10bit ADC output, otherwise this camera will use 12bit ADC.

Here is the maximum speed of ASI1600 running at 10bit ADC or 12bit ADC at 8bit mode.

Resolution	USB3.0		USB2.0	
	10Bit ADC	12Bit ADC	10Bit ADC	12Bit ADC
4656x3520	23fps	14.7fps		2.5fps
3840x2160	36.2fps	23.1fps		5fps
1920x1680	57.7fps	32.9fps		13fps
1280x960	73.6fps	47.1fps		34fps
640x480	125.7fps	80.4fps	125.7fps	80.4fps
320x240	192.4fps	124.4fps	192.4fps	124.4fps

6.7 Binning

The ASI1600 camera supports hardware and software bin2 bin3 bin4 mode. Hardware binning is supported by sensor but is done in digital domain like software binning and use 10bit ADC. The only advantage of hardware binning is faster fps. We recommend customer use software binning if you don't care speed.

6.8 Replacing the desiccant tablets

Your camera includes high-performance desiccant tablets to eliminate condensation in the CMOS chamber. Desiccant tablets are already installed in your cooled ASI camera, and the sealed packet included with your camera is for backup/replacement. You will only need to change the desiccant tablets if fogging or dew occurs inside the CMOS chamber.

To replace the desiccant tablets, you simply unscrew the front cover, take out the used desiccant tablet and replace it with a new one. Please do it in a dry place and exchange it as fast as you can. Make sure the desiccant tablets are seated into their form to prevent them from moving inside the CMOS chamber.

The desiccant tablets can keep the sensor room dry for years



But if frost shows up on sensor, it is time to exchange them

7. How to use your camera

There are many adapters available for this camera for connecting to your scope or lens. Some are included with the camera and others you can order from our site:

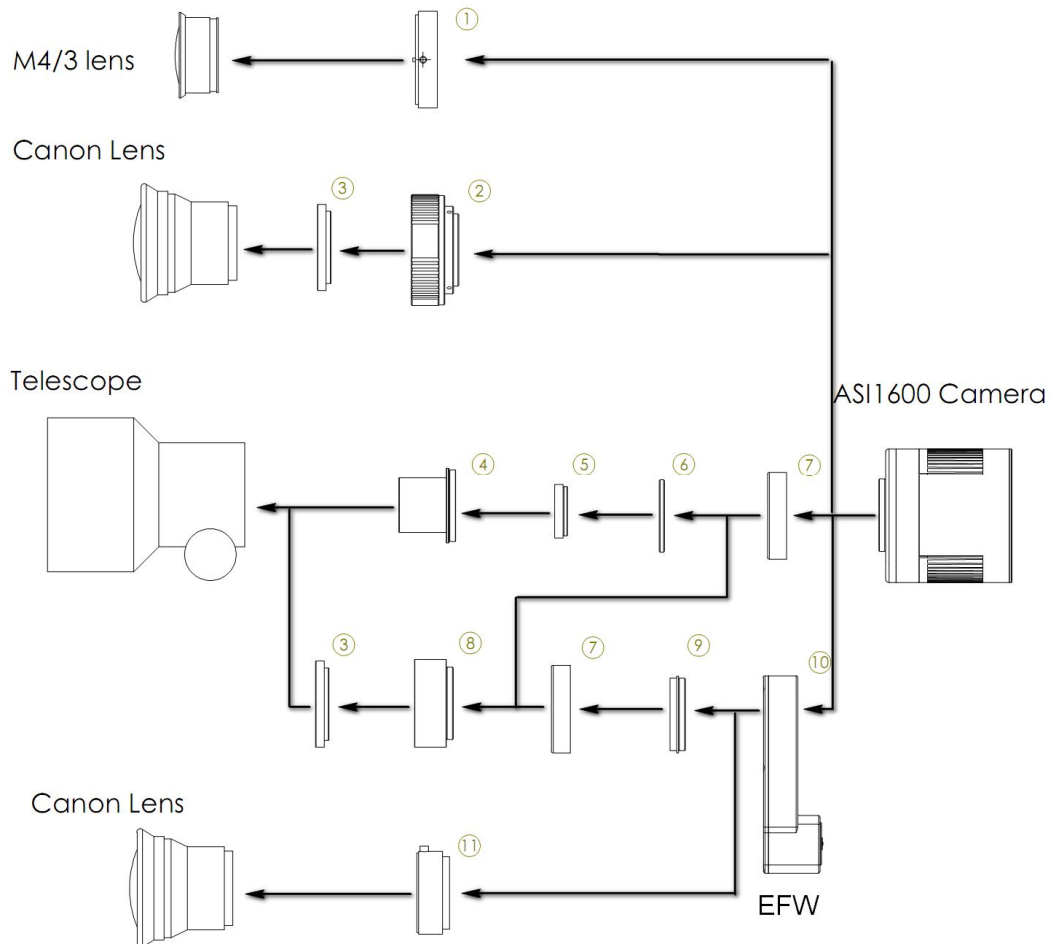

1. [M43-T2 adapter](#)
2. [EOS-T2 adapter](#)
3. 2" Filter (optional)
4. 1.25" nosepiece
5. 1.25" Filter (optional)
6. T2-1.25" Filter (optional)
7. T2 extender 11mm
8. T2-M48 extender 18.5mm
9. T2-T2 adapter
10. EFWmini
11. [EOS adapter for EFW+1600](#)

Here are the steps to show you how to connect mono 1600 and our EFWmini to your scopes. Benefiting from the short back focus design, 1.25" filter can support up to F5 scope without vignetting and 31 mm filter can support up to F2 scope without vignetting.

 <p>EFW Mini & ASI1600-C</p>	 <p>Unscrew the six screws</p>
 <p>Take the back cover off.</p>	 <p>Screw all the filters to the right position.</p>
 <p>Tighten back the screws.</p>	 <p>Screw off the T2-1.25" holder on the EFW, screw off the T2 ring on the 1600-C.</p>

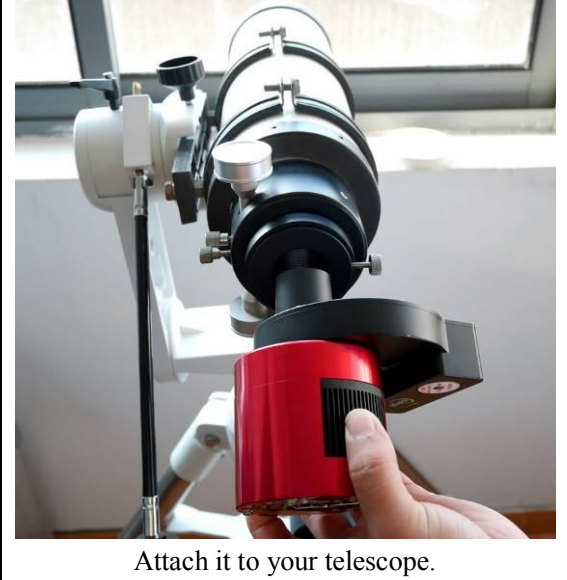

Here is an example of the whole setup including an OAG and guider camera.



8. Cleaning

The camera comes with an AR protect window, which can protect the sensor from dust and humidity. Should you need to clean the sensor, it's better to do so during the daytime. To see the dust, you just need to setup your telescope and point it to a bright place. A Barlow is required to see these dusts clear. Then attach the camera and adjust the exposure to make sure not over exposed. You can see an image like below if it's dirty.

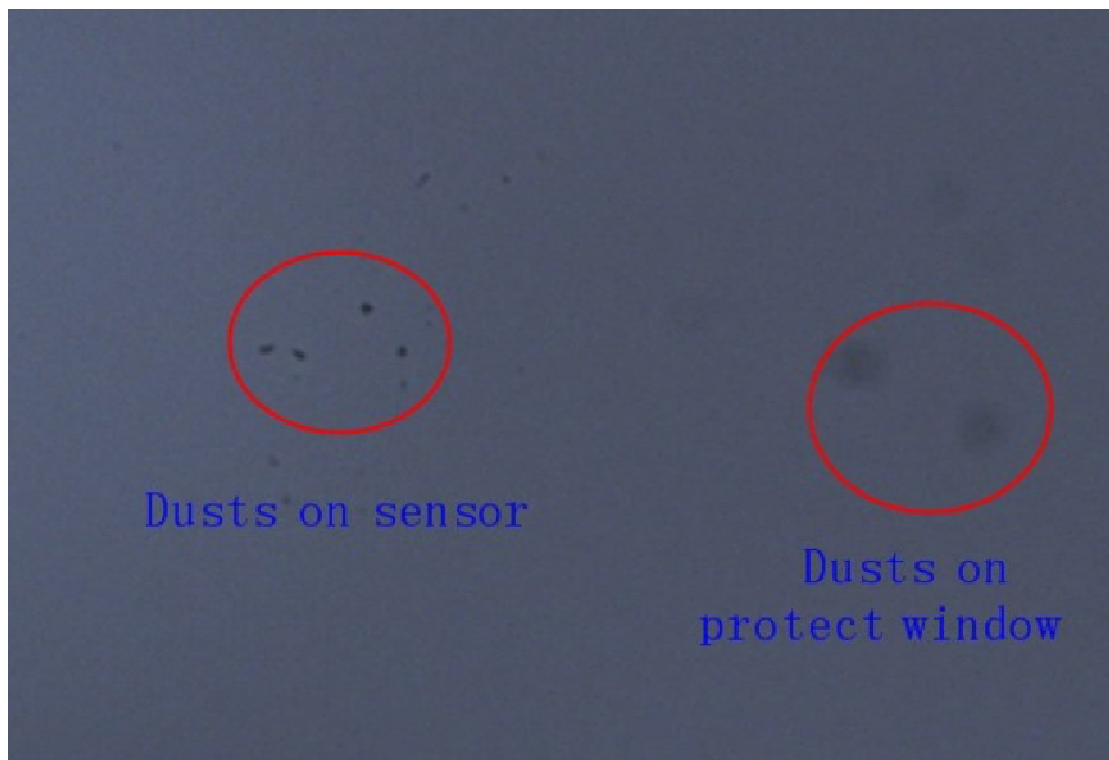

The big dim spot on the image (at right) are the shadows of dust on the protect window.

The very small but very dark spot in the image (at left) are the shadows of the dusts on the sensor.

The suggested way to clean them is try to blow them away with a manual air pump. To clean the dust on the sensor you will need to open the camera body. Simply screw off the cover by hand in a counter-clockwise direction.

Keep in mind that the sensor is an optical device and all precautions must be taken to prevent dust or scratches on the input window. If there is dirt that doesn't come off with the air pump, here are the steps to clean it.

Equipment

- Ethanol.
- Cleaning medium (wipes, optical paper, cotton buds).
- Filtered blow-off gun (preferably with static charge neutralizing capability).

- Area protected from electrostatic discharges and equipped with ground straps.

Preparations

- Wear vinyl gloves or finger cots without talcum powder.
- Make use of anti-ESD equipment: Ground straps, ionizers etc.

Recommendations

- Never clean with a dry cleaning medium.
- Soak the cleaning medium with alcohol and do not pour it directly on the window.
- Clean the window only if necessary.

Operating Procedure

- Clean the glass window with an air-jet (using the blow-off gun).
- If stains or dust remain;
 - Soak the cleaning medium with alcohol and wipe the glass window in a single movement

From one side to another.

- Always use a clean part of the cleaning medium for each new attempt.
- Adapt the speed of the wiping action to let alcohol evaporate without leaving traces.
- Optionally, use the blow-off gun to clean the window once more.

9. Mechanical drawing

ASI1600MM/ASI1600MC

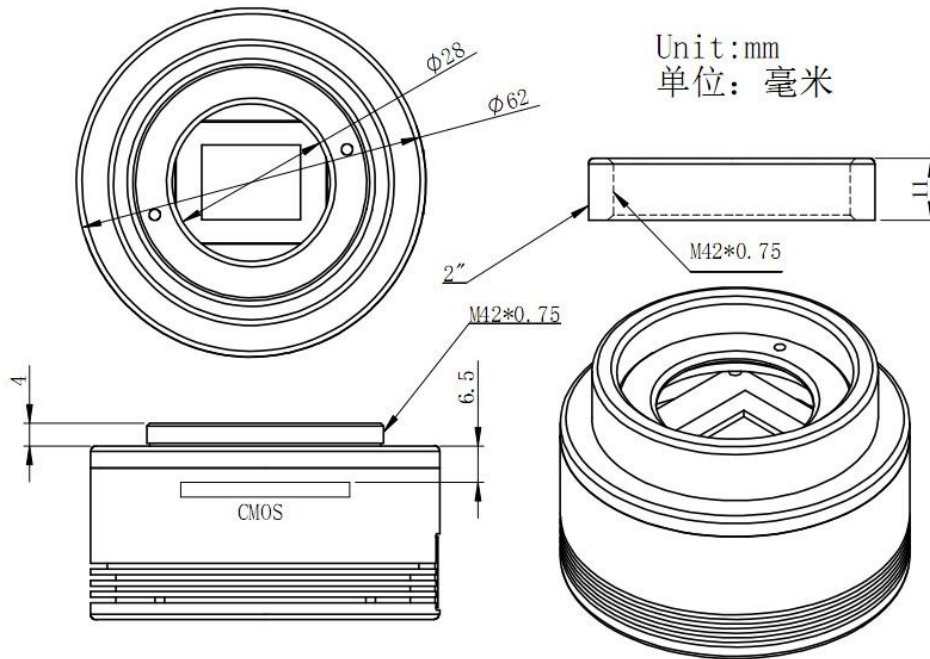

ASI1600MM-Cool/ASI1600MC-Cool

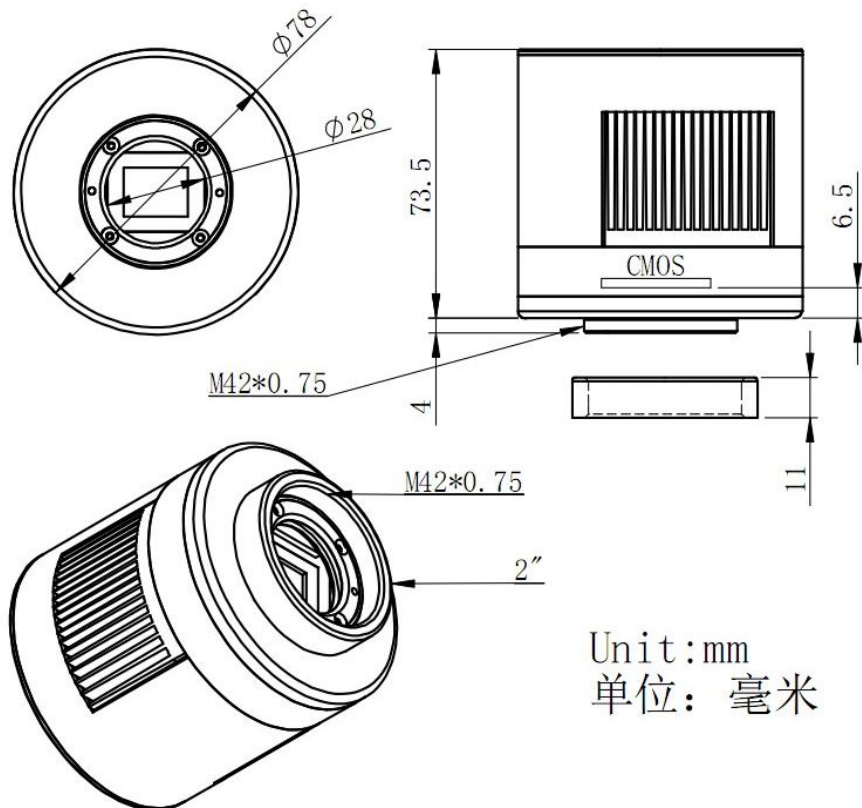

10. Servicing

Repairs, servicing and upgrades are available by emailing info@zwoptical.com

For customers who bought the camera from your local dealer, dealer is responsible for the customer service.

11. Warranty

We provide 2-year warranty for our products, we will offer repair service for free or replace for free if the camera doesn't work within warranty period.

After the warranty period, we will continue to provide repair support and service on a charged basis.

This warranty does not apply to damage that occurred as a result of abuse or misuse, or caused by a fall or any other transportation failures after purchase.

Customer must pay for shipping when shipping the camera back for repair or replacement.